

**CURTISS -
WRIGHT**

ENGINEERING SUCCESS

ANNUAL
REPORT
2017

Curtiss-Wright Corporation is a global diversified industrial company built on long-standing customer relationships, leading market positions and innovative technologies. Our legacy dates back to 1929 with the merger of companies founded by aviation pioneers Glenn Curtiss and the Wright Brothers.

Headquartered in Davidson, N.C., our team of approximately 8,600 employees is dedicated to providing outstanding service and innovative products to customers worldwide.

2017 Financial Highlights¹

| | 2015 | 2016 | 2017 |
|-----------------------------------|----------|----------|----------|
| Net Sales | \$ 2,186 | \$ 2,109 | \$ 2,271 |
| Operating Income | \$ 291 | \$ 308 | \$ 340 |
| Operating Margin | 13.3% | 14.6% | 15.0% |
| Diluted Earnings Per Share | \$ 3.74 | \$ 4.20 | \$ 4.80 |
| Free Cash Flow² | \$ 272 | \$ 376 | \$ 336 |

¹ All figures reported on a continuing operations basis. Dollars in millions, except per share data. 2015 Pro Forma results exclude the one-time China AP1000[®] fee of \$20 million recognized as revenue and operating income in the fourth quarter of 2015.

² Free cash flow is defined as cash flow from operations less capital expenditures. 2015 adjusted to remove the \$145 million contribution to the Company's corporate defined benefit pension plan.



We encourage you to read the on-line annual report at www.curtisswright.com/investors/annual-report-and-proxy



**CURTISS -
WRIGHT**

PROVIDING HIGHLY ENGINEERED
ADVANCED SOLUTIONS THAT UNIQUELY
MEET THE COMPLEX NEEDS OF TODAY'S
COMMERCIAL, INDUSTRIAL, DEFENSE
AND **POWER** MARKETS.

ENGINEERING GROWTH THROUGH INNOVATION.

A sampling of the innovation and tenacity that keeps us delivering year after year.

2017

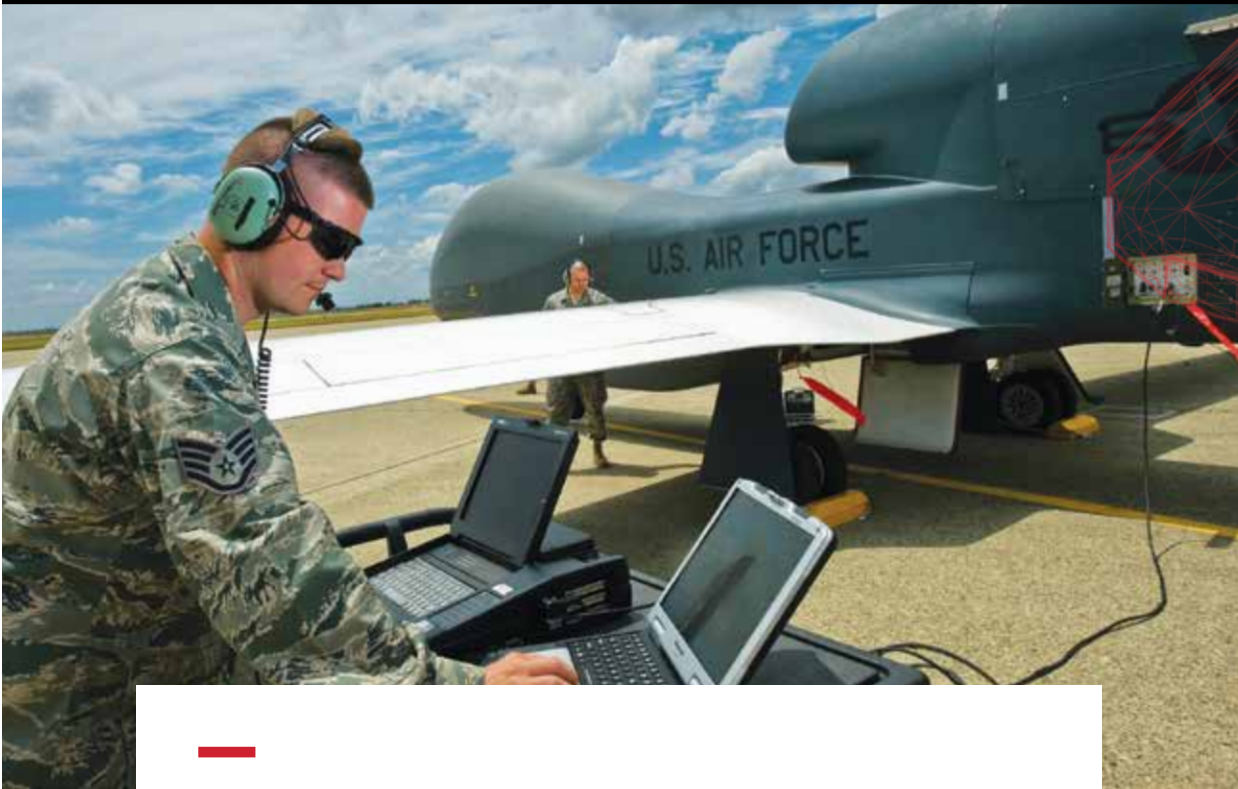

Taking Aerospace Test to New Heights: TTC Acquisition Creates Market Leading Data Acquisition Supplier

In 2017, Curtiss-Wright formed the industry's broadest and most experienced single source for customers of commercial and defense aerospace instrumentation system solutions through the combination of its Teletronics Technology Corporation (TTC) and Acra business units. As a result, we are able to leverage their collective strengths to drive product co-development and provide worldwide support. Curtiss-Wright now supports more aerospace flight test customers, platforms, and programs than any other competitor around the world with the broadest range of in-house designed system level data acquisition products. In the photo above, a USAF Flight Crew Chief performs pre-flight tests on an RQ-4B Global Hawk.

Advanced Data Server and Recorder



Axon Remote Data Acquisition Unit

2017 **Military & Aerospace Electronics**
Innovators Awards
GOLD HONOREE



DuraCOR 312
Mission Computer



VPX3-687
Ethernet Switch



OpenHPEC
Architecture
Suite

Investment in Product Innovation Recognized Across the Industry

Curtiss-Wright continuously invests in research and development to bolster its leadership position in embedded computing by maintaining existing products and developing innovative new products. In 2017, these efforts were honored by customers, suppliers, and the media. Mentor recognized Curtiss-Wright's Defense Solutions (CWDS) division with its 1st Place Technology Leadership Award for Military & Aerospace PCB design excellence. Raytheon Integrated Defense Systems presented its 5-Star Supplier Award for outstanding supplier quality performance. Additionally, five CWDS products were awarded Military & Aerospace Electronics magazine's Innovators Award.



GSX Series Integrated Motor Actuator

A More Electric World

Curtiss-Wright's expertise in electromechanical actuation (EMA) spans aviation, defense and industrial automation markets. Our actuation solutions provide the efficiency, power and durability required for critical applications as they convert to "electrification." For example, in the industrial automotive industry, our electric actuators are integrated into robotic arms (as pictured) for welding, painting, and material handling. In defense, they are used on aircraft carriers to support the Aircraft Launch and Recovery Equipment (ALRE) systems and Aircraft Elevator (ACE) lock and stanchion systems. Curtiss-Wright is creating a cleaner, more efficient electric world through our highly engineered EMA solutions.

Universal
Column Shifter

Ahead of the Curve in Shifting Trends

Curtiss-Wright launched a new Universal Column Shifter into serial production with a major North American truck OEM in 2017. From a single hardware platform, the column mounted shifter can be programmed to shift a variety of automatic transmissions from various manufacturers. This simplifies vehicle design for the OEM, giving them control over their cab design instead of having to accommodate unique shifters for each transmission. The shifter can also accommodate the engine brake function and is available in symmetrical designs for right hand and left hand installations.

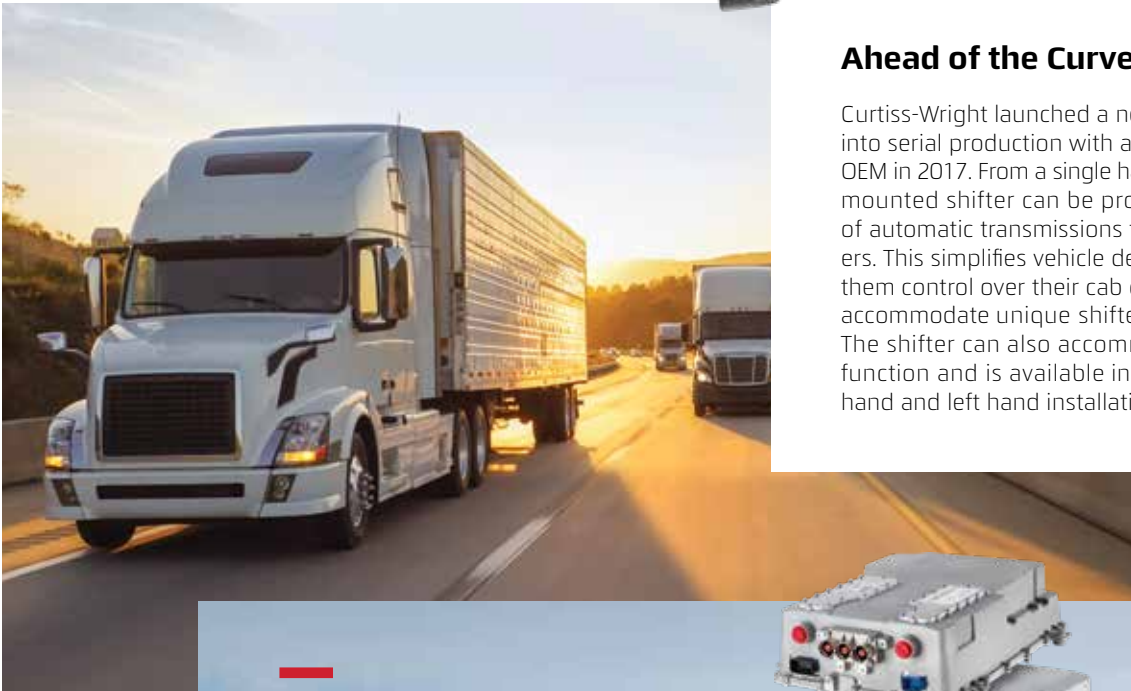

Next Generation of Protection, Reliability and Power

Curtiss-Wright has developed a new generation of traction inverters—the World Traction Inverter (WTI) family—targeted at both on- and off-highway vehicle markets. Over 16 years of design, production and in-field experience (over 1.8 billion on-road km) went into developing the WTI family, which offers unmatched protection, reliability and power density compared to today's existing traction inverters. Curtiss-Wright recently secured a contract with a global hybrid drive system supplier for transit buses, as well as a strategic partnership with a well-known system supplier, offering electrification drive systems for on- and off-highway vehicle applications.

Family
of World
Traction
Inverters



David C. Adams

Chairman and
Chief Executive Officer

DEAR FELLOW SHAREHOLDERS:

Curtiss-Wright achieved impressive results and delivered a highly successful performance in 2017.

Our team continues to execute on the vision of One Curtiss-Wright, and based on our perseverance, competitiveness and drive for increased efficiency, we have now achieved top quartile performance within our peer group for all of our key financial metrics established at our Investor Day back in December 2013. We remain focused on driving operational excellence and financial discipline in order to remain a top quartile performer. We are engineering success—building on our nearly 90 years as a public company through continued innovation and growth of our products and services, as well as developing our people—to continue to remain competitive in the global marketplace.

While we are proud of our achievements, we will not rest on our laurels and must continue to look to the future. We are positioning the Company for renewed growth by increasing our investments in capital and research and development. Innovation remains critical to the Company's long-term success and will enable us to take advantage of an improving organic growth outlook expected across all of our end markets. We intend to supplement this growth through a disciplined approach to strategic acquisitions, exemplified by our successful acquisition of Teletronics Technology Corporation (TTC) in early 2017.

15.0%

OPERATING MARGIN

\$336M

FREE CASH FLOW

MAKING HEADLINES

Announced acquisition
of Dresser-Rand
government business*

Share price reached \$125
for first time ever

Eclipsed \$5 billion in
market capitalization

Completed acquisition of
Teletronics Technology
Corporation (TTC)

*Announced Feb. 2018; Expected to close second quarter 2018. Financials in this document do not include the results of the acquisition.



As a testament to our successes this past year, our stock price continues to perform well. We exceeded \$5 billion in market capitalization for the first time in our history and in early 2018, we reached \$6 billion market capitalization.

Journey to Top Quartile Performance

In 2013, we established a five-year goal to achieve top quartile performance versus our peer group across a range of metrics, including: Operating Margin, Earnings per Share (EPS), Return on Invested Capital (ROIC), Working Capital as a percentage of Sales, Capital Expenditures and Free Cash Flow Conversion.

I'm proud to say that we've made tremendous strides as an organization. Several metrics were achieved well ahead of our original five-year target, most notably the very strong operating margin, which expanded nearly 600 basis points since we began this journey in 2013.

As a result of our excellent results in 2017, we have achieved or exceeded our original targets and reached top quartile for all metrics. The last two metrics to make the list—ROIC and Working Capital as a percentage of Sales—were achieved due to the team's laser focus and execution over the past couple of years.

We are and will continue to focus on cost improvement, leveraging the critical mass of Curtiss-Wright across the enterprise, and maintaining top quartile performance.

DEFENSE SEGMENT SALES BY END MARKET (2017)

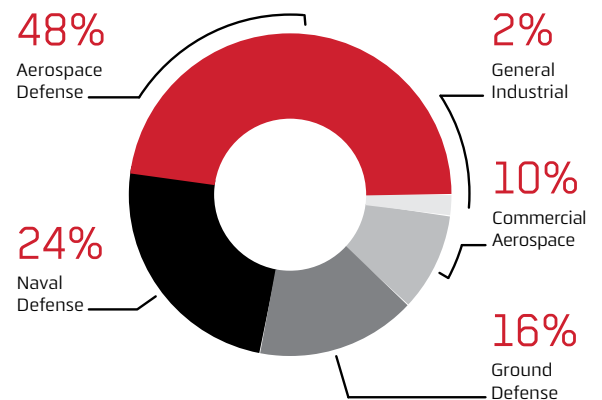

2017 Financial Performance

We achieved strong operational performance in 2017, led by solid organic sales, continued margin expansion and strong free cash flow generation.

Net sales of \$2.3 billion increased 8%, including 5% organic growth, driven by higher sales in all of our commercial and defense end markets. Of particular note was the strong rebound in our general industrial market, as several areas that had been depressed finally turned the corner, driving better than expected growth. We generated a 10% increase in operating income, as well as solid margin expansion, achieving an operating margin of 15.0%. This performance demonstrates our continual drive for execution and the benefits of our ongoing margin improvement initiatives. As a result, our diluted earnings per share increased 14% to \$4.80.

In addition, we generated \$336 million in free cash flow and a free cash flow conversion of 156%, as we efficiently reduced working capital to 18.8% of sales. Further, our balance sheet remains healthy and provides a solid base of financial flexibility to continue pursuing our growth strategies.

Balanced Capital Allocation Strategy

Curtiss-Wright remains committed to a balanced capital allocation strategy that consists of complementing our organic growth with a disciplined pace of acquisitions, reinvesting in our business (including increased research and development across all segments in 2018), and providing steady distributions to our shareholders in order to maximize shareholder value.

The Company's strong financial position and continued ability to deliver solid earnings growth and free cash flow enables us to consistently provide a steady return to our

shareholders. We maintain an active share repurchase program, where we repurchased \$51 million in shares in 2017, and also authorized a 15% increase in the quarterly dividend payout to \$0.15 per share, or \$0.60 annually. We expect to repurchase at least \$50 million in shares in 2018. Over the past four years, we have repurchased more than \$500 million of our shares.

We will also seek acquisitions that support our long-term strategic and financial objectives. In early 2017, we completed the acquisition of TTC, a leading designer and manufacturer of high-technology, comprehensive data acquisition and flight test instrumentation systems for the aerospace and defense markets. TTC was a great addition to our portfolio with its attractive positioning within a growing defense market, as well as its robust profitability.

**COMMERCIAL/INDUSTRIAL SEGMENT
SALES BY END MARKET (2017)**

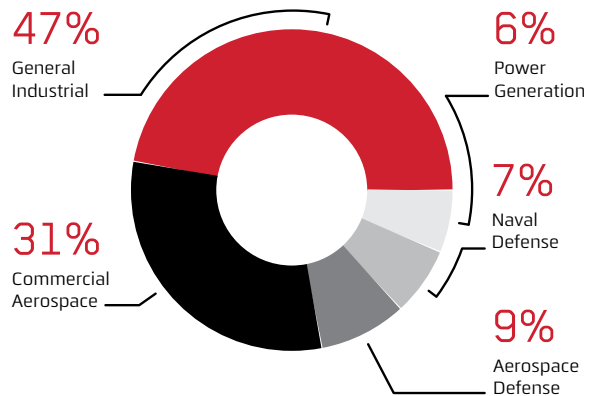



**POWER SEGMENT SALES
BY END MARKET (2017)**

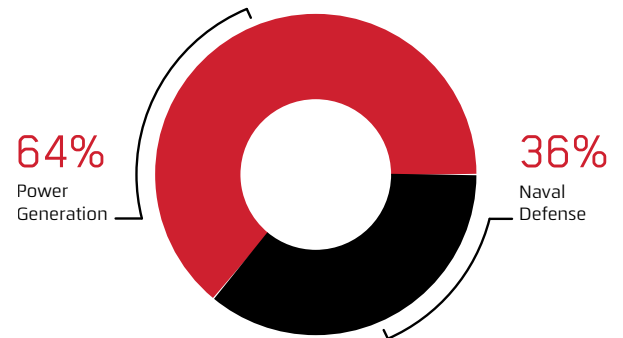

In early 2018, we announced an agreement to purchase the Dresser-Rand government business for \$212.5 million in cash. Dresser-Rand is the preferred supplier of steam turbines and main engine guard valves on aircraft carriers, and has significant content on submarines and other surface ships. As a result, this acquisition is expected to significantly expand our shipset content and increase our footprint on new U.S. Navy Nuclear vessels. It also will establish a prominent Curtiss-Wright presence at U.S. Navy shipyards and provide an opportunity to grow our existing U.S. Navy aftermarket business. We are excited to add this marquee brand to the Curtiss-Wright portfolio, especially during a period of rising naval defense budgets.

These collective actions reflect the Board of Directors' continued confidence in our ability to deliver solid, profitable growth and strong free cash flow.

Focus on Renewed Growth

As we turn our attention to 2018 and future years, we believe that we are well positioned for renewed top-line growth across our broad and highly diversified portfolio of products and services to the commercial aerospace, defense, power generation and general industrial markets.

Within the defense markets, we expect to continue to benefit from the favorable trends in military spending and increasing defense budgets, particularly as it relates to our content on critical fighter jet, submarine and aircraft carrier programs. In the commercial markets,

we expect to leverage the continued production ramp up in commercial aerospace, ongoing support for operating and new build reactors in the commercial nuclear power industry and improving global economic conditions driving our industrial businesses. As a result, we anticipate sales growth in all end markets, strong operating margin expansion and increased earnings per share, along with continued strong free cash flow in 2018.

In closing, I would like to thank our 8,600 global employees for their unwavering determination and hard work in support of the One Curtiss-Wright vision, which will ensure our continued success.

We remain committed to enhancing Curtiss-Wright's long-term shareholder value through steady organic investment supplemented with acquisitions, operating margin expansion, significant free cash flow generation and steady distributions to our shareholders, and look forward to continued successes in 2018.

Sincerely,

David C. Adams

Chairman and Chief Executive Officer

2017 FINANCIALS

SEGMENT FINANCIAL INFORMATION

Years ended December 31 (Dollars in millions, except percentages; unaudited)

| Sales | 2017 | 2016 | CHANGE |
|-----------------------|-------------------|-------------------|---------------|
| Commercial/Industrial | \$ 1,162.7 | \$ 1,118.8 | 4% |
| Defense | 555.5 | 466.6 | 19% |
| Power | 552.9 | 523.5 | 6% |
| Total Sales | \$ 2,271.0 | \$ 2,108.9 | 8% |

Operating Income (Expense)

| | | | |
|-------------------------------|-----------------|-----------------|------------|
| Commercial/Industrial | \$ 168.3 | \$ 156.5 | 8% |
| Defense | 109.4 | 98.3 | 11% |
| Power | 85.3 | 76.5 | 11% |
| Total Segments | \$ 362.9 | \$ 331.3 | 10% |
| Corporate & Other | (23.2) | (23.2) | 0% |
| Total Operating Income | \$ 339.7 | \$ 308.1 | 10% |

Operating Margins

| | | |
|--------------------------------|--------------|--------------|
| Commercial/Industrial | 14.5% | 14.0% |
| Defense | 19.7% | 21.1% |
| Power | 15.4% | 14.6% |
| Segment Margins | 16.0% | 15.7% |
| Total Operating Margins | 15.0% | 14.6% |

Note: Amounts may not add to the total due to rounding.

END MARKET SALES

39%
Defense

24%
General Industrial

19%
Power Generation

18%
Commercial Aerospace



HISTORICAL FINANCIAL PERFORMANCE

THREE-YEAR REVIEW

Years ended December 31 (Dollars in millions, except percentages; unaudited)

| Performance⁽¹⁾ | 2017 | 2016 | 2015 |
|----------------------------------|-------------|-------------|-------------|
| Net sales | \$ 2,271.0 | \$ 2,108.9 | \$ 2,205.7 |
| Operating income | \$ 339.7 | \$ 308.1 | \$ 310.6 |
| Operating margin | 15.0% | 14.6% | 14.1% |
| Net earnings | \$ 214.9 | \$ 189.4 | \$ 192.2 |

Earnings Per Share⁽¹⁾

| | | | |
|---------------------|---------|---------|---------|
| Basic | \$ 4.86 | \$ 4.27 | \$ 4.12 |
| Diluted | \$ 4.80 | \$ 4.20 | \$ 4.04 |
| Dividends per share | \$ 0.56 | \$ 0.52 | \$ 0.52 |

Year-end Financial Position

| | | | |
|--|------------|------------|------------|
| Return on invested capital ⁽²⁾ | 13.6% | 12.0% | 11.5% |
| New orders | \$ 2,290.2 | \$ 2,149.2 | \$ 2,585.0 |
| Backlog | \$ 2,011.1 | \$ 1,950.8 | \$ 1,928.7 |
| Working capital as % of sales ⁽³⁾ | 18.8% | 21.0% | 25.4% |
| Total assets | \$ 3,236.3 | \$ 3,037.8 | \$ 2,989.6 |
| Total debt | \$ 814.1 | \$ 966.3 | \$ 953.2 |
| Stockholder's equity | \$ 1,527.8 | \$ 1,291.2 | \$ 1,255.4 |

Other Year-end Data

| | | | |
|--|----------|----------|----------|
| Cash flow from operations | \$ 388.7 | \$ 423.2 | \$ 162.5 |
| Capital expenditures | \$ 52.7 | \$ 46.8 | \$ 35.5 |
| Free cash flow ⁽⁴⁾ | \$ 336.0 | \$ 376.4 | \$ 272.0 |
| EBITDA | \$ 439.7 | \$ 404.1 | \$ 411.4 |
| Depreciation & amortization | \$ 100.0 | \$ 96.0 | \$ 100.8 |
| Shares of stock outstanding at December 31 | 44.1 | 44.2 | 44.6 |
| Number of registered shareholders ⁽⁵⁾ | 3,532 | 3,770 | 4,038 |
| Number of employees ⁽⁵⁾ | 8,626 | 7,946 | 8,421 |

Note: Amounts may not add due to rounding.

(1) Reported on a continuing operations basis.

(2) Return on invested capital is equal to net operating profit after-tax over two-year average net debt plus equity and excludes equity from discontinued operations.

(3) Working capital is equal to accounts receivable plus inventory minus accounts payable, deferred income and deferred development costs.

(4) Free cash flow is defined as cash flow from operations less capital expenditures. 2015 adjusted to remove the \$145 million contribution to the Company's corporate defined benefit pension plan.

(5) Actual number, not in millions.

DIRECTORS

David C. Adams

Chairman and Chief Executive Officer;
Director, Snap-On Incorporated

Dean M. Flatt

Director, Ducommun, Inc. and Industrial Container Services (ICS), LLC; Former President and Chief Operating Officer of Honeywell International's Defense and Space Business

S. Marce Fuller

Former President and Chief Executive Officer of Mirant Corporation, Inc. (formerly known as Southern Energy, Inc.)

Rita J. Heise

Director, Fastenal Company; Former Corporate Vice President and Chief Information Officer of Cargill, Incorporated

Bruce D. Hoechner

President and Chief Executive Officer, and a Director, of Rogers Corporation

Dr. Allen A. Kozinski

Former Vice President of Global Refining of British Petroleum PLC

John B. Nathman

Admiral, U.S. Navy (Ret.)

Robert J. Rivet

Former Executive Vice President, Chief Operations, and Administrative Officer of Advanced Micro Devices, Inc.

Albert E. Smith

Director, Tetra Tech, Inc. and CDI Corporation; Former Executive Vice President of Lockheed Martin Corporation

Peter C. Wallace

Director, Applied Industrial Technologies, Inc. and Rogers Corporation; Former Chief Executive Officer and Director of Gardner Denver Inc.; Former President, Chief Executive Officer, and Director of Robbins & Myers, Inc

OFFICERS

David C. Adams

Chairman and Chief Executive Officer

Glenn E. Tynan

Vice President and Chief Financial Officer

Thomas P. Quinly

Vice President and Chief Operating Officer

Paul J. Ferdenzi

Vice President, General Counsel, and Corporate Secretary

Harry S. Jakubowitz

Vice President and Treasurer

K. Christopher Farkas

Vice President of Finance and Corporate Controller

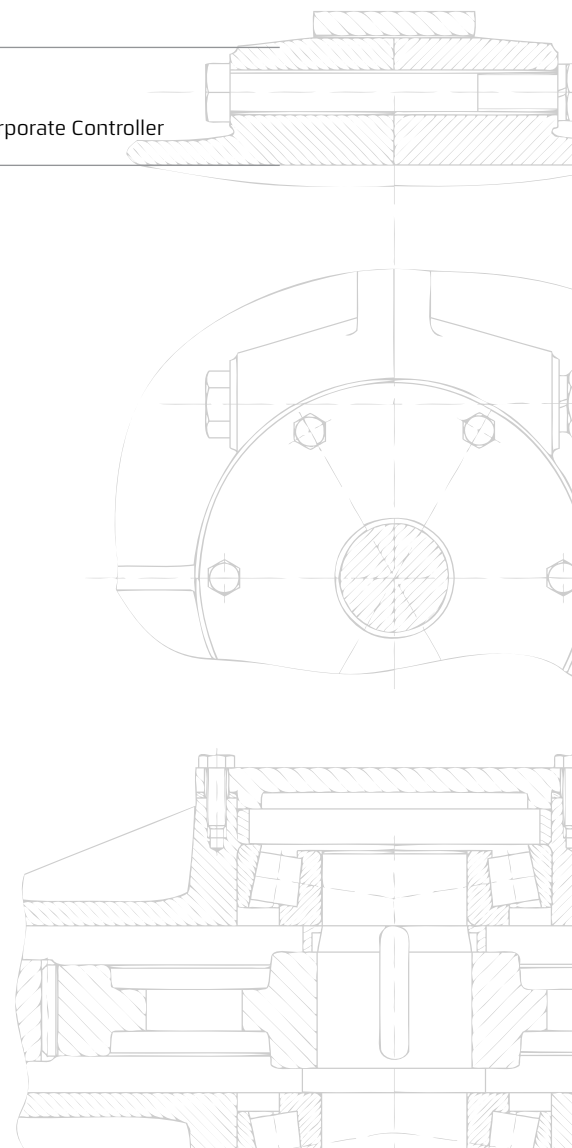

***CURTISS -
WRIGHT***

ENGINEERING SUCCESS

—

2017
FORM 10-K

**UNITED STATES
SECURITIES AND EXCHANGE COMMISSION
WASHINGTON, D.C. 20549**

FORM 10-K

**[X] ANNUAL REPORT PURSUANT TO SECTION 13 OR 15(d) OF
THE SECURITIES EXCHANGE ACT OF 1934**

For the fiscal year ended December 31, 2017

or

**[] TRANSITION REPORT PURSUANT TO SECTION 13 OR 15(d) OF
THE SECURITIES EXCHANGE ACT OF 1934**

For the transition period from _____ to _____.
Commission File Number 1-134

CURTISS-WRIGHT CORPORATION

(Exact name of Registrant as specified in its charter)

Delaware
(State or other jurisdiction of
incorporation or organization)

13-0612970
(I.R.S. Employer Identification No.)

**13925 Ballantyne Corporate Place,
Suite 400, Charlotte, North Carolina**
(Address of principal executive offices)

28277
(Zip Code)

Registrant's telephone number, including area code: (704) 869-4600

Securities registered pursuant to Section 12(b) of the Act:

Title of each class

Name of each exchange on which registered

Common stock, par value \$1 per share

New York Stock Exchange

Securities registered pursuant to Section 12(g) of the Act:

None

Indicate by check mark if the registrant is a well-known seasoned issuer, as defined in Rule 405 of the Securities Act. Yes No

Indicate by check mark if the registrant is not required to file reports pursuant to Section 13 or Section 15(d) of the Act. Yes No

Indicate by check mark whether the Registrant (1) has filed all reports required to be filed by Section 13 or 15(d) of the Securities Exchange Act of 1934 during the preceding 12 months (or for such shorter period that the registrant was required to file such reports), and (2) has been subject to such filing requirements for the past 90 days. Yes No

Indicate by check mark whether the Registrant has submitted electronically and posted on its corporate Web site, if any, every Interactive Data File required to be submitted and posted pursuant to Rule 405 of Regulation S-T (§232.405 of this chapter) during the preceding 12 months (or for such shorter period that the registrant was required to submit and post such files). Yes No

Indicate by check mark if disclosure of delinquent filers pursuant to Item 405 of Regulation S-K (§ 229.405 of this chapter) is not contained herein, and will not be contained, to the best of registrant's knowledge, in definitive proxy or information statements incorporated by reference in Part III of this Form 10-K or any amendment to this Form 10-K.

Indicate by check mark whether the registrant is a large accelerated filer, an accelerated filer, a non-accelerated filer, or a smaller reporting company. See the definitions of "large accelerated filer," "accelerated filer" and "smaller reporting company" in Rule 12b-2 of the Exchange Act.

Large accelerated filer

Accelerated filer

Non-accelerated filer (Do not check if a smaller reporting company) Smaller reporting company Emerging growth company

If an emerging growth company, indicate by check mark if the registrant has elected not to use the extended transition period for complying with any new or revised financial accounting standards provided pursuant to Section 13(a) of the Exchange Act.

Indicate by check mark whether the registrant is a shell company (as defined in Rule 12b-2 of the Exchange Act). Yes No

The aggregate market value of the voting and non-voting Common stock held by non-affiliates of the Registrant as of June 30, 2017 was approximately \$3.6 billion.

The number of shares outstanding of the Registrant's Common stock as of January 31, 2018:

Class
Common stock, par value \$1 per share

Number of shares
44,154,677

DOCUMENTS INCORPORATED BY REFERENCE

Portions of the Proxy Statement of the Registrant with respect to the 2018 Annual Meeting of Stockholders to be held on May 10, 2018 are incorporated by reference into Part III of this Form 10-K.

INDEX TO FORM 10-K

PART I

| | | |
|----------|---------------------------|----|
| Item 1. | Business | 1 |
| Item 1A. | Risk Factors | 5 |
| Item 1B. | Unresolved Staff Comments | 14 |
| Item 2. | Properties | 14 |
| Item 3. | Legal Proceedings | 14 |
| Item 4. | Mine Safety Disclosures | 15 |

PART II

| | | |
|----------|--|----|
| Item 5. | Market for the Registrant's Common Equity, Related Stockholder Matters and Issuer Purchases of Equity Securities | 16 |
| Item 6. | Selected Financial Data | 19 |
| Item 7. | Management's Discussion and Analysis of Financial Condition and Results of Operations | 20 |
| Item 7A. | Quantitative and Qualitative Disclosures About Market Risk | 39 |
| Item 8. | Financial Statements and Supplementary Data | 41 |
| Item 9. | Changes in and Disagreements with Accountants on Accounting and Financial Disclosure | 84 |
| Item 9A. | Controls and Procedures | 84 |
| Item 9B. | Other Information | 84 |

PART III

| | | |
|----------|--|----|
| Item 10. | Directors, Executive Officers and Corporate Governance | 85 |
| Item 11. | Executive Compensation | 85 |
| Item 12. | Security Ownership of Certain Beneficial Owners and Management and Related Stockholder Matters | 85 |
| Item 13. | Certain Relationships and Related Transactions, and Director Independence | 85 |
| Item 14. | Principal Accounting Fees and Services | 85 |

PART IV

| | | |
|----------|---|----|
| Item 15. | Exhibits, Financial Statement Schedule | 86 |
| | Schedule II – Valuation and Qualifying Accounts | 91 |
| | Signatures | 92 |

PART I

FORWARD-LOOKING STATEMENTS

Except for historical information, this Annual Report on Form 10-K may be deemed to contain “forward-looking statements” within the meaning of the Private Litigation Reform Act of 1995. Examples of forward-looking statements include, but are not limited to: (a) projections of or statements regarding return on investment, future earnings, interest income, sales, volume, other income, earnings or loss per share, growth prospects, capital structure, liquidity requirements, and other financial terms, (b) statements of plans and objectives of management, (c) statements of future economic performance, (d) the effect of laws, rules, regulations, new accounting pronouncements, and outstanding litigation on our business and future performance, and (e) statements of assumptions, such as economic conditions underlying other statements. Such forward-looking statements can be identified by the use of forward-looking terminology such as “anticipates,” “believes,” “continue,” “could,” “estimate,” “expects,” “intend,” “may,” “might,” “outlook,” “potential,” “predict,” “should,” “will,” as well as the negative of any of the foregoing or variations of such terms or comparable terminology, or by discussion of strategy. No assurance may be given that the future results described by the forward-looking statements will be achieved. While we believe these forward-looking statements are reasonable, they are only predictions and are subject to known and unknown risks, uncertainties, and other factors, many of which are beyond our control, which could cause actual results, performance or achievement to differ materially from anticipated future results, performance or achievement expressed or implied by such forward-looking statements. In addition, other risks, uncertainties, assumptions, and factors that could affect our results and prospects are described in this report, including under the heading “Item 1A. Risk Factors” and elsewhere, and may further be described in our prior and future filings with the Securities and Exchange Commission and other written and oral statements made or released by us. Such forward-looking statements in this Annual Report on Form 10-K include, without limitation, those contained in Item 1. Business, Item 7. Management’s Discussion and Analysis of Financial Condition and Results of Operations, and Item 8. Financial Statements and Supplementary Data, including, without limitation, the Notes to Consolidated Financial Statements.

Given these risks and uncertainties, you are cautioned not to place undue reliance on such forward-looking statements. These forward-looking statements speak only as of the date they were made, and we assume no obligation to update forward-looking statements to reflect actual results or changes in or additions to the factors affecting such forward-looking statements.

Item 1. Business.

BUSINESS DESCRIPTION

Curtiss-Wright Corporation and its subsidiaries (we, the Corporation, or the Company) is a global, diversified manufacturing and service company that designs, manufactures, and overhauls precision components and provides highly engineered products and services to the aerospace, defense, general industrial, and power generation markets. We were formed in 1929 by the merger of companies founded by the Wright brothers and Glenn Curtiss, both aviation pioneers. We are incorporated under the laws of the State of Delaware and headquartered in Charlotte, North Carolina. We list our common stock on the New York Stock Exchange (NYSE) and trade under the symbol CW.

We expect that the diversification and breadth of our portfolio should mitigate the impact of business cycle volatility and allow us to drive growth in new products and markets. We seek to leverage and build upon our critical mass to expand our global manufacturing capabilities, sales channels and customer relationships. We strive for consistent organic sales growth, operating margin expansion, and free cash flow generation, while maintaining a disciplined and balanced capital deployment strategy in order to drive long-term shareholder value.

We are well positioned on high-performance platforms and critical applications that require our technical sophistication and benefit from decades of engineering expertise. Our technologies are relied upon to improve safety, operating efficiency, and reliability, while meeting demanding performance requirements. Our ability to provide high-performance, advanced technologies on a cost-effective basis is fundamental to our strategy to drive increased value to our customers. We compete globally, primarily based on technology and pricing.

Business Segments

We manage and evaluate our operations based on the products and services we offer and the different markets we serve. Based on this approach, we operate through three segments: Commercial/Industrial, Defense, and Power.

Our principal domestic manufacturing facilities are located in Arizona, New York, North Carolina, Ohio, and Pennsylvania, and internationally in Canada, Mexico, and the United Kingdom.

Commercial / Industrial

Sales in the Commercial/Industrial segment are primarily to the general industrial and commercial aerospace markets and, to a lesser extent, the defense and power generation markets. The businesses in this segment provide a diversified offering of highly engineered products and services including: industrial vehicle products such as electronic throttle control devices, joysticks and transmission shifters; sensors, controls and electro-mechanical actuation components and utility systems used on commercial aircraft; valves to both the industrial and naval defense markets; and surface technology services such as shot peening, laser peening, coatings and advanced analytical testing. The businesses within our Commercial/Industrial segment are impacted primarily by general economic conditions which may include consumer consumption or commercial construction rates, as the nature of their products and services primarily support global industrial, commercial aerospace, oil and gas, commercial vehicles, medical and transportation industries. As commercial industrial businesses, production and service processes rest primarily within material modification, machining, assembly, and testing and inspection at commercial grade specifications. The businesses distribute products through commercial sales and marketing channels.

Defense

Sales in the Defense segment are primarily to the defense markets and, to a lesser extent, to the commercial aerospace market. The businesses in this segment provide a diversified offering of products including: Commercial Off-the-Shelf (COTS) embedded computing board level modules, integrated subsystems, flight test equipment, instrumentation and control systems, turret aiming and stabilization products, and weapons handling systems. The businesses within our Defense segment are impacted primarily by government funding and spending, driven primarily by the U.S. Government. Our products typically support government entities in the aerospace defense, ground defense, and naval defense

industries. Additionally, we provide avionics and electronics, flight test equipment, and aircraft data management solutions to the commercial aerospace market. Our defense businesses supporting government contractors typically utilize more advanced and ruggedized production and service processes compared to our commercial businesses and have more stringent specifications and performance requirements. The businesses in this segment typically market and distribute products through regulated government contracting channels.

Power

Sales in the Power segment are primarily to the nuclear power generation market and, to a lesser extent, to the naval defense market. The businesses in this segment provide a diversified offering of products for commercial nuclear power plants and nuclear equipment manufacturers, including a wide range of hardware, pumps, valves, fastening systems, specialized containment doors, airlock hatches, spent fuel management products, and fluid sealing technologies. We also have been able to leverage existing technology and engineering expertise to provide Reactor Coolant Pump (RCP) technology, pump seals, and control rod drive mechanisms for commercial nuclear power plants, most notably to support the Westinghouse AP1000 reactor design. The power generation businesses within our Power segment are impacted by pricing and demand for various forms of energy (e.g. coal, natural gas, oil, and nuclear). The businesses are typically dependent upon the need for new construction as well as maintenance, repair and overhaul by nuclear energy providers. The businesses are subject to changes in regulation which may impact demand, consumption, and underlying supply. The production processes are primarily material modifications, machining, assembly, and testing and inspection that are typical of commercial grade or regulated specifications. The businesses distribute products through commercial sales and marketing channels and may be impacted by changes in the regulatory environment. Our products within the Power segment also support the naval defense market, where we specifically provide naval propulsion and auxiliary equipment, including main coolant pumps, power-dense compact motors, generators, and secondary propulsion systems, primarily to the U.S. Navy. The defense businesses in this segment are impacted by government funding and spending, primarily driven by the U.S. Government.

OTHER INFORMATION

Certain Financial Information

For information regarding sales by geographic region, see Note 17 to the Consolidated Financial Statements contained in Part II, Item 8, of this Annual Report on Form 10-K.

In 2017, 2016, and 2015, our foreign operations as a percentage of pre-tax earnings were 40%, 42%, and 51%, respectively.

Government Sales

Our sales to the U.S. Government and foreign government end use represented 39%, 38%, and 36% of total net sales during 2017, 2016, and 2015, respectively.

In accordance with normal U.S. Government business practices, contracts and orders are subject to partial or complete termination at any time at the option of the customer. In the event of a termination for convenience by the government, there generally are provisions for recovery of our allowable incurred costs and a proportionate share of the profit or fee on the work completed, consistent with regulations of the U.S. Government. Fixed-price redeterminable contracts usually provide that we absorb the majority of any cost overrun. In the event that there is a cost underrun, the customer recoups a portion of the underrun based upon a formula in which the customer's portion increases as the underrun exceeds certain established levels.

Generally, long-term contracts with the U.S. Government require us to invest in and carry significant levels of inventory. However, where allowable, we utilize progress payments and other interim billing practices on nearly all of these contracts, thus reducing working capital requirements. It is our policy to seek customary progress payments on certain contracts. Where we obtain such payments under U.S. Government prime contracts or subcontracts, the U.S. Government has either title to or a secured interest in the materials and work in process allocable or chargeable to the respective contracts. (See Notes 1, 4, and 5 to the Consolidated Financial Statements, contained in Part II, Item 8, of this Annual Report on Form 10-K).

Customers

We have hundreds of customers in the various industries we serve. No commercial customer accounted for more than 10% of our total sales during 2017, 2016, or 2015.

Approximately 33% of our total net sales for 2017, 32% for 2016, and 30% for 2015 were derived from contracts with agencies of, and prime contractors to, the U.S. Government. Information on our sales to the U.S. Government, including direct sales as a prime contractor and indirect sales as a subcontractor, is as follows:

| <i>(In thousands)</i> | Year Ended December 31, | | |
|-----------------------------|-------------------------|-----------|-----------|
| | 2017 | 2016 | 2015 |
| Commercial/Industrial | \$178,202 | \$187,498 | \$177,827 |
| Defense | 369,977 | 305,459 | 300,462 |
| Power | 191,733 | 181,851 | 176,737 |
| Total U.S. Government sales | \$739,912 | \$674,808 | \$655,026 |

Patents

We own and license a number of United States and foreign patents and patent applications, which have been obtained or filed over a period of years. We also license intellectual property to and from third parties. Specifically, the U.S. Government receives licenses to our patents that are developed in performance of government contracts, and it may use or authorize others to use the technology covered by such patents for government purposes. Additionally, trade secrets, unpatented research and development, and engineering, some of which have been acquired by the company through business acquisitions, make an important contribution to our business. While our intellectual property rights in the aggregate are important to the operation of our business, we do not consider the success of our business or business segments to be materially dependent upon the timing of expiration or protection of any one or group of patents, patent applications, or patent license agreements under which we now operate.

Research and Development

Company-sponsored research and development costs are expensed when incurred. Total research and development expenses amounted to \$60 million, \$59 million, and \$61 million in 2017, 2016, and 2015, respectively.

Executive Officers

| Name | Current Position | Business Experience | Age | Executive Officer Since |
|-----------------------|--|---|------------|--------------------------------|
| David C. Adams | Chairman and Chief Executive Officer | Chairman and Chief Executive Officer of the Corporation since January 2015. Prior to this, he served as President and Chief Executive Officer of the Corporation from August 2013. He also served as President and Chief Operating Officer of the Corporation from October 2012 and as Co-Chief Operating Officer of the Corporation from November 2008. He has been a Director of the Corporation since August 2013. | 63 | 2005 |
| Thomas P. Quinly | Vice President and Chief Operating Officer | Vice President of the Corporation since November 2010 and Chief Operating Officer of the Corporation since October 2013. He also served as President of Curtiss-Wright Controls, Inc. from November 2008. | 59 | 2010 |
| Glenn E. Tynan | Vice President and Chief Financial Officer | Vice President and Chief Financial Officer of the Corporation since June 2002. | 59 | 2000 |
| Paul J. Ferdenzi | Vice President, General Counsel, and Corporate Secretary | Vice President, General Counsel, and Corporate Secretary of the Corporation since March 2014. Prior to this, he served as Vice President-Human Resources of the Corporation from November 2011 and also served as Associate General Counsel and Assistant Secretary of the Corporation from June 1999 and May 2001, respectively. | 50 | 2011 |
| K. Christopher Farkas | Vice President of Finance and Corporate Controller | Vice President of Finance since December 2017. Prior to this, he served as Vice President and Corporate Controller of the Corporation from September 2014 and also served as Assistant Corporate Controller from May 2009. | 49 | 2014 |
| Harry S. Jakubowitz | Vice President and Treasurer | Vice President of the Corporation since May 2007 and Treasurer of the Corporation since September 2005. | 65 | 2007 |

Employees

At the end of 2017, we had approximately 8,600 employees, 8% of which are represented by labor unions and covered by collective bargaining agreements.

Available information

We file annual reports on Form 10-K, quarterly reports on Form 10-Q, current reports on Form 8-K, and proxy statements for our annual stockholders' meetings, as well as any amendments to those reports, with the Securities and Exchange Commission (SEC). The public may read and copy any of our materials filed with the SEC at the SEC's Public Reference Room at 100 F Street, NE, Washington, DC 20549. The public may obtain information on the operation of the Public Reference Room by calling the SEC at 1-800-SEC-0330. The SEC also maintains an Internet site at www.sec.gov that contains reports, proxy and information statements, and other information regarding issuers that file electronically with the SEC, including our filings. These reports are also available free of charge through the Investor Relations section of our web site at www.curtisswright.com as soon as reasonably practicable after we electronically file.

Item 1A. Risk Factors.

We have summarized the known, material risks to our business below. Our business, financial condition, and results of operations and cash flows could be materially and adversely impacted if any of these risks materialize. Additional risk factors not currently known to us or that we believe are immaterial may also impair our business, financial condition, and results of operations and cash flows. The risk factors below should be considered together with information included elsewhere in this Annual Report on Form 10-K as well as other required filings by us to the Securities Exchange Commission, such as our Form 10-Q's, Form 8-K's, proxy statements for our annual shareholder meetings, and subsequent amendments, if any.

Intrusion on our systems could damage our business.

We store sensitive data, including intellectual property, proprietary business information, and confidential employee information on our servers and databases. Despite our implementation of firewalls, switchgear, and other network security measures, our servers, databases, and other systems may be vulnerable to computer hackers, physical or electronic break-ins, sabotage, computer viruses, worms, and similar disruptions from unauthorized tampering with our computer systems. We continue to review and enhance our computer systems to try to prevent unauthorized and unlawful intrusions, but in the future it is possible that we may not be able to prevent all intrusions. Such intrusions could result in our network security or computer systems being compromised and possibly result in the misappropriation or corruption of sensitive information or cause disruptions in our services. We might be required to expend significant capital and resources to protect against, remediate, or alleviate problems caused by such intrusions. Any such intrusion could cause us to be non-compliant with applicable laws or regulations, subject us to legal claims or proceedings, disrupt our operations, damage our reputation, and cause a loss of confidence in our products and services, any of which could have a material adverse effect on our business, financial condition, and results of operations.

A substantial portion of our revenues and earnings depends upon the continued willingness of the U.S. Government and other customers in the defense industry to buy our products and services.

In 2017, approximately 33% of our total net sales were derived from or related to U.S. defense programs. U.S. defense spending has historically been cyclical, and defense budgets tend to rise when perceived threats to national security increase the level of concern over the country's safety. At other times, spending by the military can decrease. In August 2011, Congress enacted the Budget Control Act of 2011, which imposed spending caps and certain reductions in defense spending over a ten-year period through 2021. These spending caps and reductions, referred to as sequestration, went into effect in March 2013. Through a series of bipartisan agreements, Congress has been able to temporarily lift discretionary spending limits every year through 2017. However, future budgets beyond 2017 are uncertain with respect to overall levels of defense spending. In addition, competing demands for federal funds can put pressure on all areas of discretionary spending, which could ultimately impact the defense budget. As a result of this uncertainty, a decrease in U.S. Government defense spending or changes in spending allocation could result in one or more of our programs being reduced, delayed, or terminated. In the event one or more of our programs are reduced, delayed, or terminated for which we provide products and services

and are not offset by revenues from foreign sales, new programs, or products or services that we currently manufacture or provide, we may experience a reduction in our revenues and earnings and a material adverse effect on our business, financial condition, and results of operations and cash flows.

As a U.S. Government contractor, we are subject to a number of procurement rules and regulations.

We must comply with and are affected by laws and regulations relating to the award, administration, and performance of U.S. Government contracts. Government contract laws and regulations affect how we do business with our customers and, in some instances, impose added costs on our business. A violation of specific laws and regulations could result in the imposition of fines and penalties, the termination of our contracts, or debarment from bidding on contracts. These fines and penalties could be imposed for failing to follow procurement integrity and bidding rules, employing improper billing practices or otherwise failing to follow cost accounting standards, receiving or paying kickbacks, or filing false claims. We have been, and expect to continue to be, subjected to audits and investigations by government agencies. The failure to comply with the terms of our government contracts could harm our business reputation. It could also result in our progress payments being withheld. In some instances, these laws and regulations impose terms or rights that are more favorable to the government than those typically available to commercial parties in negotiated transactions. For example, the U.S. Government may terminate any of our government contracts and, in general, subcontracts, at its convenience as well as for default based on performance. Upon termination for convenience of a fixed-price type contract, we normally are entitled to receive the purchase price for delivered items, reimbursement for allowable costs for work-in-process, and an allowance for profit on work actually completed on the contract or adjustment for loss if completion of performance would have resulted in a loss. Upon termination for convenience of a cost reimbursement contract, we normally are entitled to reimbursement of allowable costs plus a portion of the fee. Such allowable costs would normally include our cost to terminate agreements with our suppliers and subcontractors. The amount of the fee recovered, if any, is related to the portion of the work accomplished prior to termination and is determined by negotiation.

A termination arising out of our default could have a material adverse effect on our ability to compete for future contracts and orders. In addition, on those contracts for which we are teamed with others and are not the prime contractor, the U.S. Government could terminate a prime contract under which we are a subcontractor, irrespective of the quality of our services as a subcontractor.

Our U.S. Government contracts typically span one or more base years and multiple option years. The U.S. Government generally has the right to not exercise option periods and may not exercise an option period if the agency is not satisfied with our performance on the contract or does not receive funding to continue the program. U.S. Government procurement may adversely affect our cash flow or program profitability.

Furthermore, we are subject to other risks in connection with government contracts, including without limitation:

- the frequent need to bid on programs prior to completing the necessary design, which may result in unforeseen technological difficulties and/or cost overruns;
- the difficulty in forecasting long-term costs and schedules and the potential obsolescence of products related to long-term, fixed price contracts;
- contracts with varying fixed terms that may not be renewed or followed by follow-on contracts upon expiration;
- cancellation of the follow-on production phase of contracts if program requirements are not met in the development phase; and
- the fact that government contract wins can be contested by other contractors.

Our operations are subject to numerous domestic and international laws, regulations, and restrictions. Noncompliance with these laws, regulations, and restrictions could expose us to fines, penalties, suspension, or debarment, which could have a material adverse effect on our profitability and overall financial condition.

We have contracts and operations in many parts of the world subject to United States and foreign laws and regulations, including the False Claims Act, regulations relating to import-export control (including the International Traffic in Arms Regulation promulgated under the Arms Export Control Act), technology transfer restrictions, repatriation of earnings, exchange controls, the Foreign Corrupt Practices Act, the U.K. Anti-Bribery Act, and the anti-boycott provisions of the U.S. Export Administration Act. Although we have implemented policies and procedures and provided training that we believe are sufficient to address these risks, we cannot guarantee that our operations will always comply with these laws and regulations. From time to time, we may file voluntary disclosure reports with the U.S. Department of State, the Department of Energy, and the Department of Commerce regarding certain violations of U.S. export control laws and regulations discovered by us in the course of our business activities, employee training, or internal reviews and audits. To date, our voluntary disclosures have not resulted in a fine, penalty, or export privilege denial or restriction that has had a material adverse impact on our financial condition or ability to export. Our failure, or failure by our sales representatives or consultants to comply with these laws and regulations could result in administrative, civil, or criminal liabilities and could, in the extreme case, result in suspension or debarment from government contracts or suspension of our export privileges, which could have a material adverse effect on our business.

Our business, financial condition, and results of operations could be materially adversely affected if the United States were to withdraw from or materially modify NAFTA or certain other international trade agreements, or if tariffs or other restrictions on the foreign-sourced goods that we sell were to increase.

A significant portion of our business activities are conducted in foreign countries, including Mexico and Canada. Our business benefits from free trade agreements such as the North American Free Trade Agreement (NAFTA) and we also rely on various U.S. corporate tax provisions related to international commerce as we build, market, and sell our products globally. U.S. international trade policy is uncertain under the Trump administration, including, for example, the government's decision to renegotiate the NAFTA. This could cause an increase in customs duties which in turn could adversely affect intercompany transactions among our operating subsidiaries in Canada, Mexico, and the U.S., and increase transaction costs with third party suppliers and customers. In addition, President Trump has made comments suggesting that he supports significantly increasing tariffs on goods imported into the United States from certain countries such as Mexico. At this time, it remains unclear what actions, if any, President Trump will take with respect to other international trade agreements, U.S. tax provisions related to international commerce, and tariffs on goods imported into the United States. If the United States were to withdraw from or materially modify NAFTA or other international trade agreements to which it is a party, or change corporate tax policy related to international commerce, or if tariffs were raised on the foreign-sourced goods that we sell, such goods may no longer be available at a commercially attractive price or at all. This in turn could have a material adverse effect on our business, financial condition, and results of operations.

Unanticipated changes in our tax provisions or exposure to additional income tax liabilities could affect our profitability.

Our business operates in many locations under government jurisdictions that impose income taxes. Changes in domestic or foreign income tax laws and regulations, or their interpretation, could result in higher or lower income tax rates assessed or changes in the taxability of certain revenues or the deductibility of certain expenses, thereby affecting our income tax expense and profitability. In addition, audits by income tax authorities could result in unanticipated increases in our income tax expense.

Our operating results and financial condition may be adversely impacted by the current worldwide economic conditions.

We currently generate significant operating cash flows, which combined with access to the credit markets provides us with significant discretionary funding capacity. However, financial markets in the United States, Europe, and Asia had experienced extreme disruption in previous years, which included, among other things, extreme volatility in security prices, severely diminished liquidity and credit availability, rating downgrades of certain investments, and declining valuations of others. While these conditions had not previously impaired our ability to operate our business, there can be no assurance that there will not be a further deterioration

in financial markets and confidence in major economies, which could impact customer demand for our products as well as our ability to manage normal commercial relationships with our customers, suppliers, and creditors. We are unable to predict the likely duration and severity of a disruption in financial markets and adverse economic conditions and the effects they will have on our business and financial condition.

Political and economic changes in foreign countries and markets, including foreign currency fluctuations, may have a material effect on our operating results.

During 2017, approximately 31% of our total net sales were to customers outside of the United States. Additionally, we also have operating facilities located in foreign countries. Doing business in foreign countries is subject to numerous risks, including without limitation: political and economic instability, the uncertainty of the ability of non-U.S. customers to finance purchases, restrictive trade policies, changes in the local labor-relations climate, economic conditions in local markets, health concerns, and complying with foreign regulatory and tax requirements that are subject to change. While these factors or the impact of these factors are difficult to predict, any one or more of these factors could adversely affect our operations. To the extent that foreign sales are transacted in foreign currencies and we do not enter into currency hedge transactions, we are exposed to risk of losses due to fluctuations in foreign currency exchange rates, particularly for the British Pound, Euro, and Canadian dollar. Significant fluctuations in the value of the currencies of the countries in which we do business could have an adverse effect on our results of operations.

We operate in highly competitive markets.

Many of our products and services are sold in highly competitive markets and are affected by varying degrees of competition. We compete against companies that often have higher sales volumes and greater financial, technological, research and development, human, and marketing resources than we have. As a result, they may be better able to withstand the effects of periodic economic downturns. In addition, some of our largest customers could develop the capability to manufacture products or provide services similar to products that we manufacture or services that we provide. This would result in these customers supplying their own products or services and competing directly with us for sales of these products or services, all of which could significantly reduce our revenues. Furthermore, we are facing increased international competition and cross-border consolidation of competition. Our management believes that the principal points of competition in our markets are technology, product quality, product performance, price, technical expertise, timeliness of delivery, superior customer service and support, and continued certification under customer quality requirements and assurance programs. If we are unable to compete successfully with existing or new competitors in these areas, we may experience a material adverse effect on our business, financial condition, and results of operations.

Potential product liability risks exist from the products that we sell.

We may be exposed to liabilities for personal injury, death, or property damage due to the failure of a product that we have sold. We typically agree to indemnify our customers against certain liabilities resulting from the products we sell, and any third-party indemnification we seek from our suppliers and our liability insurance may not fully cover our indemnification obligations to customers. We may also not be able to maintain insurance coverage in the future at an acceptable cost. Any liability for which third-party indemnification is not available that is not covered by insurance could have a material adverse effect on our business, financial condition, and results of operations.

In addition, an accident caused by one of our products could damage our reputation for selling quality products. We believe that our customers consider safety and reliability as key criteria in selecting our products and believe that our reputation for quality assurance is a significant competitive strength. If an accident were to be caused by one of our products, or if we were to otherwise fail to maintain a satisfactory record of safety and reliability, our ability to retain and attract customers may be materially adversely affected.

A downturn in the aircraft market could adversely affect our business.

Our sales to large commercial aircraft manufacturers are cyclical in nature and can be adversely affected by a number of factors, including current and future traffic levels, increasing fuel and labor costs, intense price competition, the retirement of older aircraft, regulatory changes, outbreak of infectious disease, terrorist attacks, general economic conditions, worldwide airline profits, and backlog levels, all of which can be unpredictable and are outside our control. Any decrease in demand resulting from a downturn in the aerospace market could adversely affect our business, financial condition, and results of operations.

If we fail to satisfy our contractual obligations, our contracts may be terminated and we may incur significant costs or liabilities, including liquidated damages and penalties.

In general, our contracts may be terminated for our failure to satisfy our contractual obligations. In addition, some of our contracts contain substantial liquidated damages provisions and financial penalties related to our failure to satisfy our contractual obligations. For example, the terms of the Electro-Mechanical Division's AP1000 China and AP1000 U.S. contracts with Westinghouse Electric Company (WEC) include liquidated damage penalty provisions for failure to meet contractual delivery dates if we caused the delay and the delay was not excusable. On October 10, 2013, we received a letter from WEC stating entitlements to the maximum amount of liquidated damages allowable under the AP1000 China contract of approximately \$25 million. To date, we have not met certain contractual delivery dates under the AP 1000 China and U.S. contracts; however there are significant uncertainties as to which parties are responsible for the delays, and we believe we have adequate legal defenses. Consequently, as a result of the above matters, we may incur significant costs or liabilities, including penalties, which could have a material adverse effect on our financial position, results of operations, or cash flows. As of December 31, 2017, the range of possible loss for liquidated damages on the WEC U.S. and China contracts is \$0 to \$55.5 million.

We are subject to liability under environmental laws.

Our business and facilities are subject to numerous federal, state, local, and foreign laws and regulations relating to the use, manufacture, storage, handling, and disposal of hazardous materials and other waste products. Environmental laws generally impose liability for investigation, remediation, and removal of hazardous materials and other waste products on property owners and those who dispose of materials at waste sites, whether or not the waste was disposed of legally at the time in question. We are currently addressing environmental remediation at certain current and former facilities, and we have been named as a potentially responsible party along with other organizations in a number of environmental clean-up sites and may be named in connection with future sites. We are required to contribute to the costs of the investigation and remediation and to establish reserves in our financial statements for future costs deemed probable and estimable. Although we have estimated and reserved for future environmental remediation costs, the final resolution of these liabilities may significantly vary from our estimates and could potentially have an adverse effect on our results of operations and financial position.

Our future growth and continued success is dependent upon our key personnel.

Our success is dependent upon the efforts of our senior management personnel and our ability to attract and retain other highly qualified management and technical personnel. We face competition for management and qualified technical personnel from other companies and organizations. Therefore, we may not be able to retain our existing management and technical personnel or fill new management or technical positions or vacancies created by expansion or turnover at our existing compensation levels. Although we have entered into change of control agreements with some members of senior management, we do not have employment contracts with our key executives. We have made a concerted effort to reduce the effect of the loss of our senior management personnel through management succession planning. The loss of members of our senior management and qualified technical personnel could have a material adverse effect on our business.

We use estimates when accounting for long-term contracts. Changes in estimates could affect our profitability and overall financial position.

Long-term contract accounting requires judgment relative to assessing risks, estimating contract revenues and costs, and making assumptions for schedule and technical issues. Due to the size and nature of many of our contracts, the estimation of total revenues and costs at completion is complicated and subject to many variables. For example, assumptions have to be made regarding the length of time to complete the contract as costs also include expected increases in wages and prices for materials. Similarly, assumptions have to be made regarding the future impact of efficiency initiatives and cost reduction efforts. Incentives, awards, price escalations, liquidated damages, or penalties related to performance on contracts are considered in estimating revenue and profit rates and are recorded when there is sufficient information to assess anticipated performance. It is possible that materially different amounts could be obtained, because of the significance of the judgments and estimation processes described above, if different assumptions were used or if the underlying circumstances were to change. Changes in underlying assumptions, circumstances, or estimates may have a material adverse effect upon future period financial reporting and performance. See "Critical Accounting Estimates and Policies" in Part II, Item 7 of this Form 10-K.

Our backlog is subject to reduction and cancellation, which could negatively impact our revenues and results of operations.

Backlog represents products or services that our customers have contractually committed to purchase from us. Total backlog includes both funded (unfilled orders for which funding is authorized, appropriated, and contractually obligated by the customer) and unfunded backlog (firm orders for which funding has not been appropriated and/or contractually obligated by the customer). We are a subcontractor to prime contractors for the vast majority of our government business; as such, substantially all amounts in backlog are funded. Backlog excludes unexercised contract options and potential orders under ordering type contracts (e.g. Indefinite Delivery / Indefinite Quantity). Backlog is adjusted for changes in foreign exchange rates and is reduced for contract cancellations and terminations in the period in which they occur. Backlog as of December 31, 2017 was \$2.0 billion. Backlog is subject to fluctuations and is not necessarily indicative of future sales. The U.S. Government may unilaterally modify or cancel its contracts. In addition, under certain of our commercial contracts, our customers may unilaterally modify or terminate their orders at any time for their convenience. Accordingly, certain portions of our backlog can be cancelled or reduced at the option of the U.S. Government and commercial customers. Our failure to replace cancelled or reduced backlog could negatively impact our revenues and results of operations.

We may be unable to protect the value of our intellectual property.

Obtaining, maintaining, and enforcing our intellectual property rights and avoiding infringing on the intellectual property rights of others are important factors to the operation of our business. While we take precautionary steps to protect our technological advantages and intellectual property and rely in part on patent, trademark, trade secret, and copyright laws, we cannot assure that the precautionary steps we have taken will completely protect our intellectual property rights. Because patent applications in the United States are maintained in secrecy until either the patent application is published or a patent is issued, we may not be aware of third-party patents, patent applications, and other intellectual property relevant to our products that may block our use of our intellectual property or may be used in third-party products that compete with our products and processes. When others infringe on our intellectual property rights, the value of our products is diminished, and we may incur substantial litigation costs to enforce our rights. Similarly, we may incur substantial litigation costs and the obligation to pay royalties if others claim we infringed on their intellectual property rights. When we develop intellectual property and technologies with funding from U.S. Government contracts, the government has the royalty-free right to use that property.

In addition to our patent rights, we also rely on unpatented technology, trade secrets, and confidential information. Others may independently develop substantially equivalent information and techniques or otherwise gain access to or disclose our technology. We may not be able to protect our rights in unpatented technology, trade secrets, and confidential information effectively. We require each of our employees and consultants to execute a confidentiality agreement at the commencement of an employment or consulting relationship with us. There is no guarantee that we will succeed in obtaining and retaining executed agreements from all employees or consultants. Moreover, these agreements may not provide effective protection of our information or, in the event of unauthorized use or disclosure, they may not provide adequate remedies.

Our future financial results could be adversely impacted by asset impairment charges.

As of December 31, 2017, we had goodwill and other intangible assets, net of accumulated amortization, of approximately \$1,426 million, which represented approximately 44% of our total assets. Our goodwill is subject to an impairment test on an annual basis and is also tested whenever events and circumstances indicate that goodwill may be impaired. Intangible assets (other than goodwill) are generally amortized over the useful life of such assets. In addition, from time to time, we may acquire or make an investment in a business that will require us to record goodwill based on the purchase price and the value of the acquired assets. We may subsequently experience unforeseen issues with such business that adversely affect the anticipated returns of the business or value of the intangible assets and trigger an evaluation of the recoverability of the recorded goodwill and intangible assets for such business. Future determinations of significant write-offs of goodwill or intangible assets as a result of an impairment test or any accelerated amortization of other intangible assets could have a material adverse impact on our financial condition and results of operations.

Our current debt, and debt we may incur in the future, could adversely affect our business and financial position.

As of December 31, 2017, we had \$814 million of debt outstanding. Our level of debt could have significant consequences for our business including: requiring us to use our cash flow to pay the principal and interest on our debt, reducing funds available for acquisitions and other investments in our business, making us vulnerable to economic downturns and increases in interest rates, limiting us from obtaining additional debt, and impacting our ability to pay dividends.

A percentage of our workforce is employed under collective bargaining agreements.

Approximately 8% of our workforce is employed under collective bargaining agreements, which from time to time are subject to renewal and negotiation. We cannot ensure that we will be successful in negotiating new collective bargaining agreements, that such negotiations will not result in significant increases in the cost of labor, or that a breakdown in such negotiations will not result in the disruption of our operations. Although we have generally enjoyed good relations with both our unionized and non-unionized employees, we may experience an adverse impact on our operating results if we are subject to labor actions.

Our earnings and margins depend in part on subcontractor performance, as well as raw material and component availability and pricing.

Our businesses depend on suppliers and subcontractors for raw materials and components. At times subcontractors perform services that we provide to our customers. We depend on these subcontractors and vendors to meet their contractual obligations in full compliance with customer requirements. Nonperformance or underperformance by subcontractors and vendors could materially impact our ability to perform obligations to our customers, which could result in a customer terminating our contract for default, expose us to liability, and substantially impair our ability to compete for future contracts and orders. Generally, raw materials and purchased components are available from a number of different suppliers, though several suppliers are our sole source of certain components. If a sole-source supplier should cease or otherwise be unable to deliver such components, our operating results could be adversely impacted. In addition, our supply networks can sometimes experience price fluctuations. Our ability to perform our obligations as a prime contractor may be adversely affected if one or more of these suppliers are unable to provide the agreed-upon supplies or perform the agreed-upon services in a timely and cost-effective manner. While we have attempted to mitigate the effects of increased costs through price increases, there are no assurances that higher prices can effectively be passed through to our customers or that we will be able to fully offset the effects of higher raw materials costs through price increases on a timely basis.

Our business involves risks associated with complex manufacturing processes.

Our manufacturing processes depend on certain sophisticated and high-value equipment. Unexpected failures of this equipment may result in production delays, revenue loss, and significant repair costs. In addition, equipment failures could result in injuries to our employees. Moreover, the competitive nature of our businesses requires us to continuously implement process changes intended to achieve product improvements and manufacturing efficiencies. These process changes may at times result in production delays, quality concerns, and increased costs. Any disruption of operations at our facilities due to equipment failures or process interruptions could have a material adverse effect on our business.

The airline industry is heavily regulated, and if we fail to comply with applicable requirements, our results of operations could suffer.

Governmental agencies throughout the world, including the U.S. Federal Aviation Administration (FAA) and the European Aviation Safety Agency, prescribe standards and qualification requirements for aircraft components, including virtually all commercial airline and general aviation products. Specific regulations vary from country to country, although compliance with FAA requirements generally satisfies regulatory requirements in other countries. We include documentation with our products sold to aircraft manufacturing customers certifying that each part complies with applicable regulatory requirements and meets applicable standards of airworthiness established by the FAA or the equivalent regulatory agencies in other countries. In order to sell our products, the Corporation as well as the products we manufacture must also be certified by our individual original equipment manufacturers (OEM) customers. If any of the material authorizations or approvals qualifying us to supply our products is revoked or suspended, then the sale of the such product would be prohibited by law, which would have an adverse effect on our business, financial condition, and results of operations.

From time to time, the FAA or equivalent regulatory agencies in other countries propose new regulations or changes to existing regulations, which are usually more stringent than existing regulations. If these proposed regulations are adopted and enacted, we may incur significant additional costs to achieve compliance, which could have a material adverse effect on our business, financial condition, and results of operations.

Our future success will depend, in part, on our ability to develop new technologies.

Virtually all of the products produced and sold by us are highly engineered and require sophisticated manufacturing and system-integration techniques and capabilities. The commercial and government markets in which we operate are characterized by rapidly changing technologies. The product and program needs of our government and commercial customers change and evolve regularly. Accordingly, our future performance depends in part on our ability to: identify emerging technological trends in our current and target markets, develop and manufacture competitive products, systems, and services, enhance our offerings by adding technological innovations that differentiate our products, systems, and services from those of our competitors, and develop, manufacture, and bring those products, systems, and service to market quickly at cost-effective prices.

We self-insure health benefits and may be adversely impacted by unfavorable claims experience.

We are self-insured for our health benefits. If the number or severity of claims increases, or we are required to accrue or pay additional amounts because the claims prove to be more severe than our original assessment, our operating results would be adversely affected. Our future claims expense might exceed historical levels, which could reduce our earnings. We expect to periodically assess our self-insurance strategy. We are required to periodically evaluate and adjust our claims reserves to reflect our experience. However, ultimate results may differ from our estimates, which could result in losses over our reserved amounts. In addition, because we do not carry “stop loss” insurance, a significant increase in the number of claims that we must cover under our self-insurance retainage could adversely affect our profitability.

Increasing costs of certain employee and retiree benefits could adversely affect our financial position, results of operations, or cash flows.

Our earnings may be positively or negatively impacted by the amount of income or expense we record for our pension and other postretirement benefit plans. U.S. GAAP requires that we calculate income or expense for the plans using actuarial valuations. These valuations reflect assumptions relating to financial markets and other economic conditions. Changes in key economic indicators can change the assumptions. The most significant year-end assumptions used to estimate pension or other postretirement benefit expense for the following year are the discount rate, the expected long-term rate of return on plan assets, expected future medical cost inflation, and expected compensation increases. In addition, we are required to make an annual measurement of plan assets and liabilities, which may result in a significant change to equity through a reduction or increase to other comprehensive income. For a discussion regarding how our financial statements can be affected by pension and other postretirement benefit plans accounting policies, see “Management’s Discussion and Analysis—Critical Accounting Estimates and Policies—Pension and Other Postretirement Benefits” in Part II, Item 7 of this Form 10-K. Although U.S. GAAP expense and pension or other postretirement contributions are not directly related, the key economic factors that affect U.S. GAAP expense would also likely affect the amount of cash we would contribute to the pension or other postretirement plans. Potential pension contributions include both mandatory amounts required under federal law, Employee Retirement Income Security Act, and discretionary contributions to improve the plans’ funded status. An obligation to make contributions to pension plans could reduce the cash available for working capital and other corporate uses.

Implementing our acquisition strategy involves risks, and our failure to successfully implement this strategy could have a material adverse effect on our business.

As part of our capital allocation strategy, we aim to grow our business by selectively pursuing acquisitions to supplement our organic growth. We are continuing to actively pursue additional acquisition opportunities, some of which may be material to our business and financial performance. Although we have been successful with this strategy in the past, we may not be able to grow our business in the future through acquisitions for a number of reasons, including:

- Encountering difficulties identifying and executing acquisitions;
- Increased competition for targets, which may increase acquisition costs;
- Consolidation in our industry, reducing the number of acquisition targets;
- Competition laws and regulations preventing us from making certain acquisitions; and
- Acquisition financing not being available on acceptable terms or at all.

In addition, there are potential risks associated with growing our business through acquisitions, including the failure to successfully integrate and realize the expected benefits of an acquisition. For example, with any past or future acquisition, there is the possibility that:

- The business culture of the acquired business may not match well with our culture;
- Technological and product synergies, economies of scale, or cost reductions may not occur as expected;
- Management may be distracted from overseeing existing operations by the need to integrate acquired businesses;
- We may acquire or assume unexpected liabilities;
- We may experience unforeseen difficulties in integrating operations and systems;
- We may fail to retain or assimilate employees of the acquired business;
- We may experience problems in retaining customers or integrating customer bases; and
- We may encounter difficulties in entering new markets in which we may have little or no experience.

Failure to successfully implement our acquisition strategy, including successfully integrating acquired businesses, could have a material adverse effect on our business, financial condition, and results of operations.

Future terror attacks, war, natural disasters, or other events beyond our control could adversely impact our businesses.

Despite our concerted effort to minimize risk to our production capabilities and corporate information systems and to reduce the effect of unforeseen interruptions through business continuity planning and disaster recovery plans, we could be adversely impacted by terror attacks, war, natural disasters such as hurricanes, floods, tornadoes, pandemic diseases, or other events such as strikes by the workforce of a significant customer or supplier. These risks could negatively impact demand for or supply of our products and could also cause disruption to our facilities or systems, which could also interrupt operational processes and adversely impact our ability to manufacture our products and provide services and support to our customers. We operate facilities in areas of the world that are exposed to natural disasters. Financial difficulties of our customers, delays by our customers in production of their products, high fuel prices, the concern of another major terrorist attack, and the overall decreased demand for our products could adversely affect our operating results and financial condition.

Item 1B. Unresolved Staff Comments.

None.

Item 2. Properties.

Our corporate headquarters is located at a leased facility in Charlotte, North Carolina. As of December 31, 2017, we had 174 facilities worldwide, including four corporate and shared-services facilities. Approximately 87% of our facilities operate as manufacturing and engineering, metal treatment, or aerospace overhaul plants, while the remaining 13% operate as selling and administrative office facilities. The number and type of facilities utilized by each of our reportable segments are summarized below:

| Owned Facilities Location | Commercial/ Industrial | Defense | Power | Total |
|---------------------------|---------------------------|---------|-------|-------|
| North America | 15 | 1 | 3 | 19 |
| Europe | 14 | 1 | — | 15 |
| Total | 29 | 2 | 3 | 34 |

| Leased Facilities Location | Commercial/ Industrial | Defense | Power | Total |
|----------------------------|---------------------------|---------|-------|-------|
| North America | 54 | 12 | 22 | 88 |
| Europe | 28 | 4 | — | 32 |
| Asia | 16 | — | — | 16 |
| Total | 98 | 16 | 22 | 136 |

The buildings on the properties referred to in this Item are well maintained, in good condition, and are suitable and adequate for the uses presently being made of them. Management believes the productive capacity of our properties is adequate to meet our anticipated volume for the foreseeable future.

Item 3. Legal Proceedings.

In the ordinary course of business, the Corporation and its subsidiaries are subject to various pending claims, lawsuits, and contingent liabilities. We do not believe that the disposition of any of these matters, individually or in the aggregate, will have a material adverse effect on our consolidated financial condition, results of operations, and cash flows.

In December 2013, the Corporation, along with other unaffiliated parties, received a claim from Canadian Natural Resources Limited (CNRL), which was filed in the Court of Queen's Bench of Alberta, Judicial District of Calgary. The claim pertains to a January 2011 fire and explosion at a delayed coker unit at its Fort McMurray refinery that resulted in the injury of five CNRL employees, damage to property and equipment, and various forms of consequential loss such as loss of profit, lost opportunities, and business interruption. The fire and explosion occurred when a CNRL employee bypassed certain safety controls and opened an operating coker unit. The total quantum of alleged damages arising from the incident has not been finalized, but is estimated to meet or exceed \$1 billion. We maintain various forms of commercial, property and casualty, product liability, and other forms of insurance; however, such insurance may not be adequate to cover the costs associated with a judgment against us. In October 2017, all parties agreed in principle to participate in a formal mediation in late 2018 with the intention of settling this claim. In an effort to induce the parties to participate in the formal mediation, CNRL agreed to reduce its claim to approximately \$400 million, which reflects the monetary amount of property damage incurred as result of the fire and explosion. We are currently unable to estimate an amount, or range of potential losses, if any, from this matter. We believe that we have adequate legal defenses and intend to defend this matter vigorously. Our financial condition, results of operations, and cash flows could be materially affected during a future fiscal quarter or fiscal year by unfavorable developments or outcome regarding this claim.

We have been named in pending lawsuits that allege injury from exposure to asbestos. To date, we have not been found liable or paid any material sum of money in settlement in any case. We believe that the minimal use of asbestos in our past operations and the relatively non-friable condition of asbestos in our

products make it unlikely that we will face material liability in any asbestos litigation, whether individually or in the aggregate. We maintain insurance coverage for these potential liabilities and we believe adequate coverage exists to cover any unanticipated asbestos liability.

On March 29, 2017, WEC filed for Chapter 11 bankruptcy protection in the United States Bankruptcy Court for the Southern District of New York, Case No. 17-10751. The Bankruptcy Court overseeing the Bankruptcy Case approved, on an interim basis, an \$800 million Debtor-in-Possession Financing Facility to help WEC finance its business operations during the reorganization process. On January 4, 2018, WEC announced that it had agreed to be acquired by Brookfield Business Partners L.P. for approximately \$4.6 billion, with the acquisition expected to close in the third quarter of 2018. The acquisition is not expected to have a material impact on our financial condition or results of operations as WEC plans to continue operating in the ordinary course of business under existing senior management.

We have approximately \$4.9 million in pre-petition billings outstanding with WEC as of December 31, 2017. On January 29, 2018, we received notice that WEC filed its Plan of Reorganization. Under the Plan, we are expected to recover substantially all of our general unsecured claims, including pre-petition billings. The Plan of Reorganization is subject to approval, with voting tentatively scheduled for March 15, 2018. As it relates to our post-petition work, we will continue to honor our executory contracts and expect to collect all amounts due. We will continue to monitor and evaluate the status of the WEC bankruptcy and Plan of Reorganization for potential impacts on our business.

Item 4. Mine Safety Disclosures.

Not applicable.

PART II

Item 5. Market for the Registrant's Common Equity, Related Stockholder Matters and Issuer Purchases of Equity Securities.

MARKET INFORMATION

Our common stock is listed and traded on the New York Stock Exchange (NYSE) under the symbol CW.

| Stock Price Range | 2017 | | 2016 | |
|---------------------|----------|---------|---------|---------|
| | High | Low | High | Low |
| Common Stock | | | | |
| First Quarter | \$100.74 | \$89.00 | \$75.93 | \$62.57 |
| Second Quarter | 95.21 | 82.77 | 87.76 | 73.95 |
| Third Quarter | 106.63 | 91.18 | 91.65 | 81.52 |
| Fourth Quarter | 125.00 | 104.12 | 107.61 | 83.48 |

As of January 1, 2018, we had approximately 3,532 registered shareholders of our common stock, \$1.00 par value.

DIVIDENDS

During 2017 and 2016, the Company paid quarterly dividends as follows:

| | 2017 | 2016 |
|---------------------|--------|--------|
| Common Stock | | |
| First Quarter | \$0.13 | \$0.13 |
| Second Quarter | 0.13 | 0.13 |
| Third Quarter | 0.15 | 0.13 |
| Fourth Quarter | 0.15 | 0.13 |

SECURITIES AUTHORIZED FOR ISSUANCE UNDER EQUITY COMPENSATION PLANS

The following table sets forth information regarding our equity compensation plans as of December 31, 2017, the end of our most recently completed fiscal year:

| Plan category | Number of securities to be issued upon exercise of outstanding options, warrants, and rights | Weighted average exercise price of outstanding options, warrants, and rights | Number of securities remaining available for future issuance under equity compensation plans (excluding securities reflected in the first column) |
|--|--|--|---|
| Equity compensation plans approved by security holders | 670,503 (a) | \$54.17 | 2,095,542 (b) |
| Equity compensation plans not approved by security holders | None | Not applicable | Not applicable |

(a) Consists of 628,780 shares issuable upon exercise of outstanding options and vesting of performance share units, restricted shares, restricted stock units, and shares to non-employee directors under the 2005 and 2014 Omnibus Incentive Plan, 41,723 shares issuable under the Employee Stock Purchase Plans.

(b) Consists of 1,797,887 shares available for future option grants under the 2014 Omnibus Incentive Plan, 297,655 shares remaining available for issuance under the Employee Stock Purchase Plan.

Issuer Purchases of Equity Securities

The following table provides information about our repurchases of equity securities that are registered by us pursuant to Section 12 of the Securities Exchange Act of 1934, as amended, during the quarter ended December 31, 2017.

| | Total Number of shares purchased | Average Price Paid per Share | Total Number of Shares Purchased as Part of a Publicly Announced Program | Maximum Dollar amount of shares that may yet be Purchased Under the Program |
|-----------------------------------|----------------------------------|------------------------------|--|---|
| October 1 – October 31 | 39,723 | \$ 110.73 | 453,486 | \$158,179,901 |
| November 1 – November 30 | 35,198 | 119.29 | 488,684 | 153,981,300 |
| December 1 – December 31 | 37,410 | 122.69 | 526,094 | 149,391,468 |
| For the quarter ended December 31 | 112,331 | \$ 117.39 | 526,094 | \$149,391,468 |

On December 7, 2016, the Corporation announced the authorization of an additional \$100 million to the share repurchase program. The Company initiated the program in January 2017 and repurchased over \$50 million of shares in 2017. On November 30, 2017, the Corporation authorized \$50 million of share repurchases in 2018. The Company has approximately \$149 million remaining under the current share repurchase authorization as of December 31, 2017, \$50 million of which will be allocated to the 10b5-1 program mentioned above. The remaining portion will be available to repurchase additional shares opportunistically through a supplemental program in 2018. Under the current program, shares may be purchased on the open market, in privately negotiated transactions, and under plans complying with Rules 10b5-1 and 10b-18 under the Securities Exchange Act of 1934, as amended.

The following performance graph does not constitute soliciting material and should not be deemed filed or incorporated by reference into any of our other filings under the Securities Act or the Securities Exchange Act of 1934, except to the extent we specifically incorporate this information by reference therein.

PERFORMANCE GRAPH

The following graph compares the annual change in the cumulative total return on our common stock during the last five fiscal years with the annual change in the cumulative total return of the Russell 2000 Index, the S&P MidCap 400 Index, and our self-constructed proxy peer group. The proxy peer group companies are as follows:

- AAR Corp
- Crane Co.
- Cubic Corp
- EnPro Industries Inc.
- Esterline Technologies Corp
- Hexcel Corp
- IDEX Corporation
- ITT Corp
- Kaman Corp
- Moog Inc.
- Orbital ATK, Inc.
- Rockwell Collins Inc.
- Spirit Aerosystems Holdings Inc.
- Teledyne Technologies Inc.
- TransDigm Group Inc.
- Triumph Group Inc.
- Woodward Inc.

The graph assumes an investment of \$100 on December 31, 2012 and the reinvestment of all dividends paid during the following five fiscal years.

COMPARISON OF CUMULATIVE FIVE YEAR TOTAL RETURN

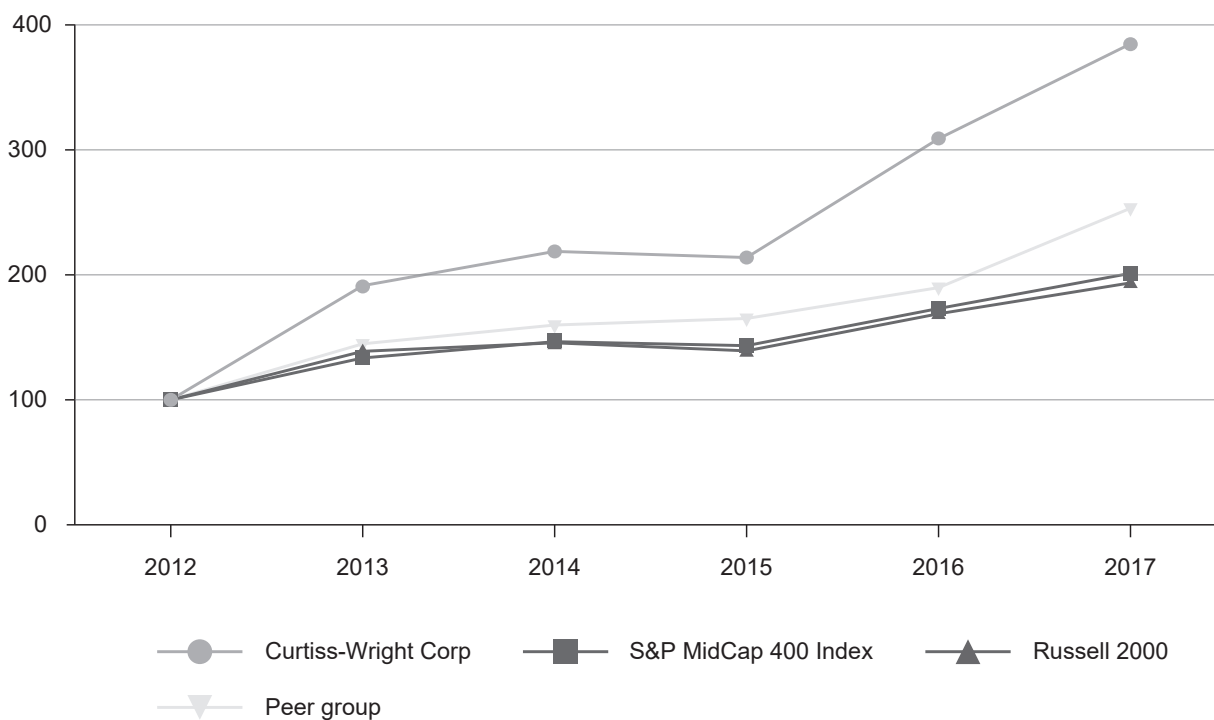

| Company / Index | 2012 | 2013 | 2014 | 2015 | 2016 | 2017 |
|---------------------------------|------------|--------|--------|--------|--------|--------|
| Curtiss-Wright Corp | 100 | 191.35 | 218.76 | 213.87 | 308.93 | 384.81 |
| S&P MidCap 400 Index | 100 | 133.50 | 146.54 | 143.35 | 173.08 | 201.20 |
| Russell 2000 | 100 | 138.82 | 145.62 | 139.19 | 168.85 | 193.58 |
| Peer group | 100 | 144.83 | 159.86 | 165.10 | 189.78 | 253.28 |

Item 6. Selected Financial Data.

The following table presents our selected financial data from continuing operations. The table should be read in conjunction with Item 7, *Management's Discussion and Analysis of Financial Condition and Results of Operations*, and Item 8, *Financial Statements and Supplementary Data*, of this Annual Report on Form 10-K.

Five-Year Financial Highlights

| | CONSOLIDATED SELECTED FINANCIAL DATA | | | | |
|--|--------------------------------------|-------------|-------------|-------------|-------------|
| <i>(In thousands, except per share data)</i> | 2017 | 2016 | 2015 | 2014 | 2013 |
| Net sales | \$2,271,026 | \$2,108,931 | \$2,205,683 | \$2,243,126 | \$2,118,081 |
| Earnings from continuing operations | 214,891 | 189,382 | 192,248 | 169,949 | 139,404 |
| Total assets | 3,236,321 | 3,037,781 | 2,989,611 | 3,382,448 | 3,458,274 |
| Total debt, net | 814,139 | 966,298 | 953,205 | 954,348 | 959,938 |
| Earnings per share from continuing operations: | | | | | |
| Basic | \$ 4.86 | \$ 4.27 | \$ 4.12 | \$ 3.54 | \$ 2.97 |
| Diluted | \$ 4.80 | \$ 4.20 | \$ 4.04 | \$ 3.46 | \$ 2.91 |
| Cash dividends per share | \$ 0.56 | \$ 0.52 | \$ 0.52 | \$ 0.52 | \$ 0.39 |

Item 7. Management’s Discussion and Analysis of Financial Condition and Results of Operations.

Our Management’s Discussion and Analysis of Financial Condition and Results of Operations begins with an overview of our company, followed by economic and industry-wide factors impacting our company and the markets we serve, a discussion of the overall results of continuing operations, and finally a more detailed discussion of those results within each of our reportable operating segments.

COMPANY ORGANIZATION

Curtiss-Wright Corporation and its subsidiaries is a global, diversified, industrial provider of highly engineered, technologically advanced, products and services to a broad range of industries which are reported through our Commercial/Industrial, Defense, and Power segments. We are positioned as a market leader across a diversified array of niche markets through engineering and technological leadership, precision manufacturing, and strong relationships with our customers. We provide products and services to a number of global markets, including the commercial aerospace, defense, general industrial, and power generation markets. Our overall strategy is to be a balanced and diversified company, less vulnerable to cycles or downturns in any one market, with a focus on establishing and expanding strong technological breadth, market positions, and financial performance.

Impacts of inflation, pricing, and volume

We have not historically been and do not expect to be significantly impacted by inflation. Increases in payroll costs and any increases in raw material costs that we have encountered are generally able to be offset through lean manufacturing activities. We have consistently made annual investments in capital that deliver efficiencies and cost savings. The benefits of these efforts generally offset the margin impact of competitive pricing conditions in all of the markets we serve.

Analytical Definitions

Throughout management’s discussion and analysis of financial condition and results of operations, the terms “incremental” and “organic” are used to explain changes from period to period. The term “incremental” is used to highlight the impact acquisitions had on the current year results for which there was no comparable prior-year period. Therefore, the results of operations for acquisitions are incremental for the first twelve months from the date of acquisition. The remaining businesses are referred to as the “organic”. The definition of “organic” excludes the effect of foreign currency translation.

Market Analysis and Economic Factors

Economic Factors Impacting Our Markets

Curtiss-Wright Corporation is a global, diversified manufacturing and service company that designs, manufactures, and overhauls precision components and provides highly engineered products and services to the aerospace, defense, general industrial, and power generation markets. Many of Curtiss-Wright’s industrial businesses are driven in large part by global economic growth, primarily led by operations in the U.S., Canada, Europe, and China.

The U.S. economy, as measured by real gross domestic product (GDP), has slowly improved since 2009, aided by decreased levels of unemployment, improvements in the housing market and a low interest rate environment. In 2017, U.S. GDP showed modest growth of 2.3%, according to the most recent estimate, led by an acceleration in growth beginning in the second quarter of 2017, while U.S. GDP grew 1.5% in 2016 and 2.6% in 2015. Looking ahead to 2018, economists have mixed views on the broader U.S. economy, with current estimates for U.S. real GDP growth indicating a rate of growth between 2% and 3%, despite the new administration’s goal to raise the pace of expansion to 4% per year through increased fiscal stimulus.

Meanwhile, the global environment continues to experience a rebound in activity that began in the second half of 2016 and gained further momentum in 2017. As a result, 2018 GDP growth in world economies is expected to grow by approximately 3.9%, up from 3.7% in 2017, according to the International Monetary Fund. This outlook is expected to be driven by broad based improvement in U.S. and European

economies, as well as an improved outlook for emerging market and developing economies. Looking ahead to the next few years, we remain cautiously optimistic that our economically-sensitive commercial and industrial markets will improve based on normalized global conditions.

Defense

We have a well-diversified portfolio of products and services that supply all branches of the U.S. military, with content on many high performance programs and platforms, as well as a growing international defense business. A significant portion of our defense business operations is attributed to the United States market, and characterized by long-term programs and contracts driven primarily by the Department of Defense (DoD) budgets and funding levels. Approximately 38% of our 2018 revenues are expected to be generated from defense-related markets.

The U.S. Defense budget serves as a leading indicator of our growth in the defense market. Following across-the-board sequestration mandated by the Budget Control Act of 2011 (Budget Control Act), defense spending and related supplemental budgets declined through 2015. However, growth has stabilized in recent years. The FY2018 Defense budget request, which began in October 2017, was \$574.5 billion (base) or \$639.1 billion (including base plus overseas contingency operations), showing growth of 8% compared to the prior year period. Congress initially passed a Continuing Resolution in December 2017, and after a brief government shutdown in early January 2018, it initiated a second Continuing Resolution to avert a Government shutdown. As a result, the DoD began the year by essentially maintaining funding at the previous year's levels. However, on February 9, 2018, the President signed a bill which is expected to provide relief on the spending caps associated with the Budget Control Act. This newly enacted legislation is expected to increase domestic defense spending by \$165 billion over two years. As a result, the proposed FY2019 Defense budget, which begins in October 2018, is expected to provide the DoD with additional stability and flexibility to enter into multi-year contracts without the impact of sequestration.

We derive revenue from the naval defense, aerospace defense, and ground defense markets. In the naval defense market, we expect continued solid funding for the U.S. shipbuilding program, particularly as it relates to production on the Ford class aircraft carrier, as well as the Columbia class and Virginia class submarine programs. We have a long legacy of providing products that support nuclear propulsion systems on naval vessels. In the aerospace defense market, we expect to benefit from increased funding levels on Command, Control, Communications, Computers, Intelligence, Surveillance, and Reconnaissance, electronic warfare, unmanned systems, and communications programs. As a leading supplier of COTS and COTS+ solutions, we continue to demonstrate that electronics technology will enhance our ability to design and develop future generations of advanced systems and products for high performance applications, while also meeting the military's Size, Weight, and Power considerations. We are also a leading designer and manufacturer of high-technology data acquisition and comprehensive flight test instrumentation systems. In the ground defense market, the modernization of the existing U.S. ground vehicle fleet is expected to recover slowly, while international demand should remain solid, particularly for our turret drive stabilization systems (TDSS).

While we monitor the budget process as it relates to programs in which we participate, we cannot predict the ultimate impact of future DoD budgets, which tend to fluctuate year-by-year and program-by-program. As a result, there may be budget reductions and program cancellations that would negatively impact programs in which we participate.

Commercial Aerospace

Curtiss-Wright derives revenue from the global commercial aerospace market, principally to the commercial jet market, and to a lesser extent the regional jet and commercial helicopter markets. Our primary focus in this market is OEM products and services for commercial jets, which is highly dependent on new aircraft production. We provide a combination of flight control and utility actuation systems, sensors, and other sophisticated electronics, as well as shot and laser peening services, to our primary customers, Boeing and Airbus. Shot and laser peening are also utilized on highly stressed components of turbine engine fan blades, landing gear, and aircraft structures.

Steady growth in airline travel, along with the demand for and delivery of new aircraft to replace an aging fleet, continue to be key drivers in the commercial aerospace market. Fiscal 2011 marked the beginning of a multi-year production up-cycle for the commercial aerospace market. This up-cycle is expected to continue through the end of the decade based on planned increases in production by Boeing and Airbus on both legacy and new aircraft, and is further supported by their strong backlogs. Additionally, the steady decline in oil prices during the past few years has been a key contributor to increased passenger growth, as declining fuel prices have led to cheaper airfares for consumers. According to the International Air Transport Association, air travel continues to be strong and is likely to display growth of approximately 6.0% in 2018, which is growing faster than the 20-year trend. Industry data supports a continued, steady increase in commercial aircraft deliveries to meet this growing demand.

While we closely monitor these industry metrics, our success and future growth in the commercial aerospace market is primarily tied to the growth in aircraft production rates, the timing of our order placement, and continued partnering with aerospace original equipment manufacturers.

Power Generation

We derive revenue from the commercial nuclear power generation market, where we supply a variety of highly engineered products and services, including reactor coolant pumps, control rod drive mechanisms, valves, motors, spent fuel management, containment doors, bolting solutions, enterprise resource planning, plant process controls, and coating services. We provide equipment and services to both the aftermarket and new build markets and have content on every reactor operating in the U.S. today.

According to the Nuclear Regulatory Commission (NRC), nuclear power comprises approximately 20% of all the electric power produced in the United States, with 99 reactors operating across 59 nuclear power plants in 30 states. Our growth opportunities for aftermarket products and services are driven by plant aging, plant closures, requirements for planned outages, 20-year plant life extensions (as they reach the end of their original 40-year operating lives), the levying of regulatory requirements, suppliers abandoning the commercial nuclear market, and plants seeking technology and innovation advances. Longer term, the NRC is considering the extension of operating licenses beyond 60 years, potentially out to 80 years.

The industry's most significant challenge is electricity market competitiveness, primarily driven by sustained low natural gas prices. As a result, the industry has been tasked with reassessing operating practices, improving efficiency, and reducing costs to help keep nuclear power competitive in a changing electricity market, which are collectively referred to as Delivering the Nuclear Promise. Additionally, U.S. reactor operators were faced with increased security and post-Fukushima regulatory requirements over the past few years. All of these factors contributed to plant operators diverting and deferring their typical plant capital expenditure budgets significantly away from planned maintenance. However, in late 2017, as those necessary requirements abated and plant operators resumed a more normalized maintenance schedule, the industry began to turn the corner. As a result, we expect increased opportunities for our vast portfolio of advanced nuclear technologies beginning in 2018.

Longer term, there are several factors that are expected to drive global commercial nuclear power demand. The Energy Information Administration forecasts that worldwide total energy consumption is expected to increase at an average annual rate of 1.0% through 2050. Continued growth in global demand for electricity, especially in developing countries with limited supply such as China and India, will require increased capacity. In addition, the continued supply constraints and environmental concerns attributed to the current dependence on fossil fuels have led to a greater appreciation of the value of nuclear technology as the most efficient and environmentally friendly source of energy available today. As a result, we expect growth opportunities in this market both domestically and internationally, although the timing of orders remains uncertain.

We also play an important role in the new build market for the Westinghouse AP1000 reactor design, for which we are a supplier of RCPs and also expect to supply a variety of ancillary plant products and services. Domestically, two new build reactors remain under construction in Georgia utilizing the AP1000 design. On a global basis, nuclear plant construction is active. Currently, there are approximately 57 new reactors under construction across 15 countries, with approximately 158 planned and 351 proposed over the next several decades. In particular, China intends to expand its nuclear power capabilities significantly through the construction of new nuclear power plants, including 2 AP1000 plants (4 reactors) currently in

the final stages of construction, that are expected to be the first Generation III design in operation, with several more new plant builds on the horizon. We continue to expect to play a role in China's growing nuclear power program and in the fourth quarter of 2015 were awarded a \$468 million contract for 16 RCPs and the sale of certain non-recurring rights (China Direct order).

As a result, we are positioned for strong expected new order activity for our vast array of nuclear technologies due to ongoing maintenance and upgrade requirements on operating nuclear plants, a renewed interest in products to aid safety and extend the reliability of existing reactors, and the continued emphasis on global nuclear power construction.

General Industrial

Revenue derived from our widely diversified offering to the general industrial market consists of industrial sensors and control systems, critical-function valves and valve systems, as well as surface treatment services. We supply our products and services to OEMs and aftermarket industrial customers, including the transportation, commercial trucking, off-road equipment, agriculture, construction, automotive, chemical, and oil and gas industries. Our performance in these markets is typically sensitive to the performance of the U.S. and global economies, with changes in global GDP rates and industrial production driving our sales, particularly for our surface treatment services.

One of the key drivers within our general industrial market is our sensors and controls systems products, most notably for electronic throttle controls, shift controls, joysticks, power management systems, traction control systems, serving on-and-off highway, medical mobility and specialty vehicles markets. Increased industry demand for electronic control systems and sensors has been driven by the need for improved operational efficiency, safety, repeatability, reduced emissions, enhanced functionality, and greater fuel efficiencies to customers worldwide. Key to our future growth is expanding the human-machine interface technology portfolio and providing a complete system solution to our customers. Existing and emerging trends in commercial vehicle safety, emissions control, and improved driver efficiency are propelling commercial vehicle OEMs toward higher performance subsystems. These trends are accelerating the evolution from discrete human machine interface components towards a more integrated vehicle interface architecture. Meanwhile, our surface treatment services, including shot and laser peening, engineered coatings, and analytical testing services, which are used to increase the safety, reliability, and longevity of components, are primarily driven by demand from general industrial customers.

Looking ahead, based on expectations for steadily improving global economic conditions, these businesses are likely to experience continued modest growth based on higher sales volumes and new international emissions regulations affecting several industries in which we participate.

We also service the oil and gas, chemical, and petrochemical industries through numerous industrial valve products, where nearly all of our industrial valve sales are to the downstream markets. We maintain a global maintenance, repair, and overhaul (MRO) business for our pressure-relief valve technologies as refineries opportunistically service or upgrade equipment that has been operating at or near full capacity. We also produce severe service, operation-critical valves for the power and process industries. Earlier in the decade through mid-2014, the industry had experienced solid performance driven by new exploration and expansion of sub-segments, including offshore drilling and shale gas, which boosted end-user demand. As a result of these market initiatives and reduced global economic growth, the industry experienced an excess of oil supply globally, driving a steady decline in crude oil prices throughout 2014 and 2015, as well as reducing capital expenditures. Though oil prices rebounded in late 2016 and throughout 2017 to drive some fresh optimism, they remain well below the recent 2014 peak. Despite the challenges in the oil and gas market, we have seen an industrial renaissance in the U.S. chemical industry due to plentiful, affordable natural gas, which has led to further adoption of severe service valve technology. Over the long run, we believe improved economic conditions and continued global expansion will be key drivers for future growth of our severe service and operation-critical valves serving the process industry.

RESULTS OF OPERATIONS

| (In thousands, except percentages) | Year Ended December 31, | | | Percent changes | |
|-------------------------------------|-------------------------|--------------|--------------|-----------------|---------------|
| | 2017 | 2016 | 2015 | 2017 vs. 2016 | 2016 vs. 2015 |
| Sales: | | | | | |
| Commercial/Industrial | \$ 1,162,689 | \$ 1,118,768 | \$ 1,184,791 | 4% | (6%) |
| Defense | 555,479 | 466,654 | 477,413 | 19% | (2%) |
| Power | 552,858 | 523,509 | 543,479 | 6% | (4%) |
| Total sales | \$ 2,271,026 | \$ 2,108,931 | \$ 2,205,683 | 8% | (4%) |
| Operating income: | | | | | |
| Commercial/Industrial | \$ 168,328 | \$ 156,550 | \$ 171,525 | 8% | (9%) |
| Defense | 109,355 | 98,291 | 98,895 | 11% | (1%) |
| Power | 85,260 | 76,472 | 74,987 | 11% | 2% |
| Corporate and eliminations | (23,200) | (23,215) | (34,790) | —% | 33% |
| Total operating income | \$ 339,743 | \$ 308,098 | \$ 310,617 | 10% | (1%) |
| Interest expense | 41,471 | 41,248 | 36,038 | 1% | 14% |
| Other income, net | 1,347 | 1,111 | 615 | NM | NM |
| Earnings before income taxes | 299,619 | 267,961 | 275,194 | 12% | (3%) |
| Provision for income taxes | (84,728) | (78,579) | (82,946) | 8% | (5%) |
| Earnings from continuing operations | \$ 214,891 | \$ 189,382 | \$ 192,248 | 13% | (1%) |
| New orders | \$ 2,290,155 | \$ 2,149,191 | \$ 2,585,038 | | |
| Backlog | \$ 2,011,092 | \$ 1,950,750 | \$ 1,928,727 | | |

NM - not meaningful

Components of sales and operating income growth (decrease):

| | 2017 vs. 2016 | | 2016 vs. 2015 | |
|---------------------------|---------------|------------------|---------------|------------------|
| | Sales | Operating Income | Sales | Operating Income |
| Organic | 5% | 7% | (4%) | (4%) |
| Acquisitions/divestitures | 3% | 3% | —% | —% |
| Foreign currency | —% | —% | —% | 3% |
| Total | 8% | 10% | (4%) | (1%) |

Year ended December 31, 2017 compared to year ended December 31, 2016

Sales for the year increased \$162 million, or 8%, to \$2,271 million, compared with the prior year period. On a segment basis, sales from the Commercial/Industrial, Defense, and Power segments increased \$44 million, \$89 million, and \$29 million, respectively. Changes in sales by segment are discussed in further detail in the results by business segment section below.

Operating income for the year increased \$32 million, or 10%, to \$340 million, and operating margin increased 40 basis points compared with 2016. Increases in operating income and operating margin were primarily attributable to higher production levels on the AP1000 China Direct program in our Power segment, higher volume on industrial vehicle products in the Commercial/Industrial segment, and the benefits of our ongoing margin improvement initiatives. These increases in operating income and operating margin were partially offset by first year purchase accounting costs from our TTC acquisition and an unfavorable shift in mix within our defense electronic products in the Defense segment.

Non-segment operating expense of \$23 million and **interest expense** of \$41 million were essentially flat compared to the respective prior year period.

The effective tax rates from continuing operations for 2017 and 2016 were 28.3% and 29.3%, respectively. The decrease in the effective tax rate in 2017, as compared to 2016, was primarily due to the adoption of ASU 2016-09 *Improvements to Employee Share-Based Payment Accounting* and higher research and development credits. This decrease was partially offset by the impact of the 2017 Tax Cuts and Jobs Act (the Tax Act), which increased the current year provision for income taxes by approximately \$10 million. Refer to Note 11 to the Consolidated Financial Statements for more information.

New orders increased \$141 million to \$2,290 million as of December 31, 2017, primarily due to the TTC acquisition in the Defense segment, which contributed \$70 million of new orders, and higher demand of \$56 million for our industrial vehicle products in the Commercial/Industrial segment. New orders in the Defense segment also benefited from higher demand for our defense electronics products and naval defense products of \$18 million and \$13 million, respectively. Growth in both our actuation and sensors and controls products to the aerospace defense and naval defense markets increased new orders \$30 million in the Commercial/Industrial segment. These increases were partially offset by a decrease in new orders of \$44 million in the Power segment and a decrease in naval new orders of \$37 million in the Commercial/Industrial segment due to the timing of funding. Changes in new orders by segment are discussed in further detail in the results by business segment section below.

Comprehensive income (loss)

Pension and postretirement adjustments within comprehensive income during the year ended December 31, 2017, were a \$3 million loss compared with a \$1 million loss for the prior year period. The changes were primarily due to a higher discount rate loss in 2017 versus the loss for the same assumption in the prior period. The discount rate loss was partially offset by higher asset returns in the current period versus the prior period, and higher loss amortization in 2017 compared to the prior period.

Foreign currency translation adjustments during the year ended December 31, 2017 resulted in a \$78 million gain, compared to a foreign currency translation loss of \$65 million in the comparable prior period. The comprehensive gain during the current period was primarily attributed to increases in the British Pound, Canadian dollar, and Euro with the prior period comprehensive loss primarily impacted by a decrease in the British Pound.

Year ended December 31, 2016 compared to year ended December 31, 2015

Sales for the year decreased \$97 million, or 4%, to \$2,109 million, compared with the prior year period. On a segment basis, sales from the Commercial/Industrial, Defense, and Power segments decreased \$66 million, \$11 million, and \$20 million, respectively. Changes in sales by segment are discussed in further detail below in the results from segment operations.

Operating income for the year decreased \$3 million, or 1%, to \$308 million, and operating margin increased 50 basis points compared with 2015. The decrease in operating income is primarily driven by lower sales volumes of our severe-service industrial valves and surface treatment services in the Commercial/Industrial segment. This decrease was partially offset by favorable foreign currency translation of approximately \$9 million and lower corporate expenses primarily due to a prior year period pension settlement charge of \$7 million related to the retirement of the company's former Chairman. Operating margin benefited from our margin improvement and cost containment initiatives during the current period.

Non-segment operating expense decreased \$12 million, to \$23 million, primarily due to lower pension expense as a result of a one-time pension settlement charge during the prior year period related to the retirement of the company's former Chairman.

Interest expense increased \$5 million to \$41 million, primarily due to the termination of our interest rate swaps in the first quarter of 2016.

The effective tax rates from continuing operations for 2016 and 2015 were 29.3% and 30.1%, respectively. The decrease in the effective tax rate in 2016, as compared to 2015, was primarily due to a reduction of unrecognized tax benefits and a reversal of certain valuation allowances, partially offset by lower research and development credits.

New orders decreased \$436 million to \$2,149 million at December 31, 2016, primarily due to a \$468 million order received in the Power segment in the prior year period and a decrease in new orders of \$58 million in the Defense segment. These decreases were partially offset by an increase in new orders of \$35 million in the Commercial/Industrial segment and the timing of government orders for pumps and generators of \$40 million in the Power segment. Changes in new orders by segment are discussed in further detail in the results by business segment section below.

Comprehensive income (loss)

Pension and postretirement adjustments within comprehensive income during the year ended December 31, 2016, were a \$1 million loss compared with a \$10 million loss for the prior year period. The changes were primarily due to plan asset and salary gains in 2016 versus losses for the same assumptions in the prior period. These gains were offset by discount rate losses in the current period versus gains in the prior period, and lower loss amortization due to the prior period settlement charge related to the retirement of the company's former Chairman.

Foreign currency translation adjustments during the year ended December 31, 2016, were a \$65 million loss compared with foreign currency translation losses of \$88 million in the comparable prior period. The comprehensive loss during the current period was primarily attributed to decreases in the British Pound with the prior year period impacted by decreases in the Canadian dollar.

RESULTS BY BUSINESS SEGMENT

Commercial/Industrial

Sales in the Commercial/Industrial segment are primarily generated from the general industrial and commercial aerospace markets and, to a lesser extent, the defense and power generation markets.

The following tables summarize sales, operating income and margin, and new orders within the Commercial/Industrial segment.

| <i>(In thousands, except percentages)</i> | Year Ended December 31, | | | Percent Changes | |
|---|-------------------------|--------------|--------------|-----------------|--------------|
| | 2017 | 2016 | 2015 | 2017 vs 2016 | 2016 vs 2015 |
| Sales | \$ 1,162,689 | \$ 1,118,768 | \$ 1,184,791 | 4% | (6%) |
| Operating income | 168,328 | 156,550 | 171,525 | 8% | (9%) |
| Operating margin | 14.5% | 14.0% | 14.5% | 50bps | (50bps) |
| New orders | \$ 1,234,698 | \$ 1,173,563 | \$ 1,138,581 | 5% | 3% |
| Backlog | \$ 585,556 | \$ 504,482 | \$ 456,481 | 16% | 11% |

Components of sales and operating income growth (decrease):

| | 2017 vs 2016 | | 2016 vs 2015 | |
|---------------------------|--------------|------------------|--------------|------------------|
| | Sales | Operating Income | Sales | Operating Income |
| Organic | 4% | 7% | (5%) | (11%) |
| Acquisitions/divestitures | —% | —% | —% | —% |
| Foreign currency | —% | 1% | (1%) | 2% |
| Total | 4% | 8% | (6%) | (9%) |

Year ended December 31, 2017 compared to year ended December 31, 2016

Sales increased \$44 million, or 4%, to \$1,163 million, from the comparable prior year period. In the general industrial market, we experienced higher sales of \$47 million, primarily due to increased demand for our industrial vehicle products. The commercial aerospace market benefited from higher sales of surface treatment services and actuation system products. These increases were partially offset by lower sales of \$16 million in the naval defense market, primarily due to the timing of production on the Virginia-class submarine program.

Operating income increased \$12 million, or 8%, to \$168 million, and operating margin increased 50 basis points to 14.5%. The increases in operating income and operating margin were primarily driven by ongoing margin improvement initiatives and higher sales volumes of our industrial vehicle products and surface treatment services.

New orders increased \$61 million as compared to the prior year, primarily due to growth in our industrial vehicle products of \$56 million and higher demand of \$30 million for both our actuation and sensors and controls products to the aerospace defense and naval defense markets. This increase was partially offset by a decline in naval valve new orders of \$37 million due to the timing of funding.

Year ended December 31, 2016 compared to year ended December 31, 2015

Sales decreased \$66 million, or 6%, to \$1,119 million, from the comparable prior year period. In the general industrial market, we experienced lower sales of severe-service valves to oil and gas markets of \$47 million and a reduction in sales for our industrial vehicle, medical mobility, and industrial automation products, of \$7 million, \$8 million, and \$6 million, respectively. Within the commercial aerospace market, higher sales of actuation and sensors and control products of \$19 million, primarily to Boeing, were partially offset by lower sales of surface technology services of \$15 million.

Operating income decreased \$15 million, or 9%, to \$157 million, and operating margin decreased 50 basis points to 14.0%. The decreases in operating income and operating margin were primarily driven by lower sales volumes of our severe-service industrial valves and surface treatment services. These

decreases were partially offset by the benefit of our margin improvement and cost containment initiatives as well as favorable foreign currency translation of approximately \$4 million.

New orders increased \$35 million to \$1,174 million from the prior year period, primarily due to growth in our naval valves of \$39 million and sensors and control products of \$32 million, partially offset by lower demand for our industrial vehicle products of \$23 million.

Defense

Sales in the Defense segment are primarily to the defense markets and, to a lesser extent, the commercial aerospace and the general industrial markets.

The following tables summarize sales, operating income and margin, and new orders, within the Defense segment.

| <i>(In thousands, except percentages)</i> | Year Ended December 31, | | | Percent Changes | |
|---|-------------------------|-----------|-----------|-----------------|---------------|
| | 2017 | 2016 | 2015 | 2017 vs. 2016 | 2016 vs. 2015 |
| Sales | \$555,479 | \$466,654 | \$477,413 | 19% | (2%) |
| Operating income | 109,355 | 98,291 | 98,895 | 11% | (1%) |
| Operating margin | 19.7% | 21.1% | 20.7% | (140)bps | 40bps |
| New orders | \$569,360 | \$445,230 | \$502,948 | 28% | (11%) |
| Backlog | \$547,273 | \$499,993 | \$533,004 | 9% | (6%) |

Components of sales and operating income growth (decrease):

| | 2017 vs. 2016 | | 2016 vs. 2015 | |
|---------------------------|---------------|------------------|---------------|------------------|
| | Sales | Operating Income | Sales | Operating Income |
| Organic | 5% | 4% | (1%) | (6%) |
| Acquisitions/divestitures | 14% | 8% | —% | —% |
| Foreign currency | —% | (1%) | (1%) | 5% |
| Total | 19% | 11% | (2%) | (1%) |

Year ended December 31, 2017 compared to year ended December 31, 2016

Sales increased \$89 million, or 19%, to \$555 million, from the comparable prior year period, primarily due to the incremental impact of our TTC acquisition, which contributed \$65 million in sales. Excluding the impact of TTC, sales to the aerospace defense, ground defense, and naval defense markets increased \$7 million, \$6 million, and \$9 million, respectively, while sales to the commercial aerospace market were essentially flat. The increase in sales to the aerospace defense market was primarily due to increased unmanned aerial vehicle (UAV) production and higher foreign military sales, partially offset by declines in helicopter production. The ground defense market benefited primarily from higher TDSS demand on international ground defense platforms. Sales to the naval defense market increased primarily due to higher submarine production.

Operating income increased \$11 million, or 11%, to \$109 million, compared with the same period in 2016, while operating margin decreased 140 basis points to 19.7%. The increase in operating income was driven primarily by the incremental impact of our TTC acquisition, which contributed operating income of \$7 million. Operating income also benefited from improved profitability in our avionics business, higher sales volumes in our defense electronics business, and ongoing margin improvement initiatives. Both operating income and operating margin were negatively impacted by first year purchase accounting costs from our TTC acquisition and an unfavorable shift in mix within our defense electronic products.

New orders increased \$124 million, as compared to the prior year, primarily due to the acquisition of TTC, which contributed \$70 million in new orders. New orders also benefited from higher demand for our defense electronics products and naval defense products of \$18 million and \$13 million, respectively.

Year ended December 31, 2016 compared to year ended December 31, 2015

Sales decreased \$11 million, or 2%, to \$467 million, from the comparable prior year period, primarily due to lower sales in the aerospace defense and commercial aerospace markets of \$7 million and \$6 million, respectively. The decrease in sales in the aerospace defense market was primarily due to lower foreign military sales. Sales in the commercial aerospace market decreased primarily due to lower sales of avionics and electronics products.

Operating income decreased \$1 million, or 1%, to \$98 million, compared with the same period in 2015, while operating margin increased 40 basis points to 21.1%. The decrease in operating income was driven primarily by lower sales volumes in our commercial avionics and electronics business as well as a favorable prior year adjustment of \$4 million related to the receipt of a TDSS production contract. This decrease was partially offset by the benefit of our margin improvement and cost containment initiatives as well as favorable foreign currency translation of approximately \$5 million.

New orders decreased \$58 million, as compared to the prior year, primarily due to a TDSS production contract of \$44 million received during the second quarter of 2015 as well as the timing of government orders.

Power

Sales in the Power segment are primarily to the power generation and naval defense markets.

The following tables summarize sales, operating income and margin, and new orders, within the Power segment.

| <i>(In thousands, except percentages)</i> | Year Ended December 31, | | | Percent Changes | |
|---|-------------------------|-----------|-----------|-----------------|---------------|
| | 2017 | 2016 | 2015 | 2017 vs. 2016 | 2016 vs. 2015 |
| Sales | \$552,858 | \$523,509 | \$543,479 | 6% | (4%) |
| Operating income | 85,260 | 76,472 | 74,987 | 11% | 2% |
| Operating margin | 15.4% | 14.6% | 13.8% | 80bps | 80bps |
| New orders | \$486,097 | \$530,398 | \$943,509 | (8%) | (44%) |
| Backlog | \$878,263 | \$946,275 | \$939,242 | (7%) | 1% |

Components of sales and operating income growth (decrease):

| | 2017 vs. 2016 | | 2016 vs. 2015 | |
|---------------------------|---------------|------------------|---------------|------------------|
| | Sales | Operating Income | Sales | Operating Income |
| Organic | 6% | 11% | (4%) | 2% |
| Acquisitions/divestitures | —% | —% | —% | —% |
| Foreign currency | —% | —% | —% | —% |
| Total | 6% | 11% | (4%) | 2% |

Year ended December 31, 2017 compared to year ended December 31, 2016

Sales increased \$29 million, or 6%, to \$553 million, from the comparable prior year period, primarily due to higher production revenues of \$52 million on the AP1000 China Direct program. This increase was partially offset by lower aftermarket sales of \$20 million supporting domestic nuclear operating reactors and lower total production revenues of \$13 million on the AP1000 U.S. and China programs. Within the naval defense market, sales increased \$12 million primarily due to higher production levels on CVN-80 pumps and increased development on the Columbia class submarine program.

Operating income increased \$9 million, or 11%, to \$85 million and operating margin increased 80 basis points to 15.4%. The increases in operating income and operating margin were primarily driven by higher production levels on the AP1000 China Direct program and the benefits of our ongoing margin improvement initiatives.

New orders decreased \$44 million, as compared to the prior year, as new orders to the commercial and defense markets decreased \$34 million and \$10 million, respectively. These decreases were primarily due to the timing of commercial orders received as well as the timing of customer funding.

Year ended December 31, 2016 compared to year ended December 31, 2015

Sales decreased \$20 million, or 4% to \$524 million, from the comparable prior year period, primarily due to lower sales in the power generation market. This decrease is primarily due to lower aftermarket sales of \$26 million supporting domestic and international nuclear operating reactors. Sales related to the AP1000 program were essentially flat as higher production revenues on the domestic and China Direct programs of \$19 million were mostly offset by a one-time license fee of \$20 million on the prior year China Direct order.

The decreases in the power generation market were partially offset by higher sales of \$5 million in the naval defense market. This was primarily due to higher sales of pumps and generators of \$16 million supporting the new Ohio-class replacement submarine program and higher production levels of \$5 million on the Electromagnetic Aircraft Launching System (EMALS) program. These increases were partially offset by lower sales of \$18 million of CVN-79 pumps and valves as production is substantially complete.

Operating income increased \$1 million, or 2%, to \$76 million and operating margin increased 80 basis points to 14.6%. The increases in operating income and operating margin were primarily driven by higher operating income of \$11 million due to increased production volumes on the AP1000 program and an unfavorable contract adjustment of \$11.5 million recorded during the prior year period. These increases were partially offset by a one-time license fee of \$20 million recorded during the prior year period. Within our nuclear aftermarket businesses, we experienced lower operating income and operating margin driven primarily by the unfavorable impact of sales volumes supporting domestic and international nuclear operating reactors. These decreases were partially offset by cost containment initiatives during the current period.

New orders decreased \$413 million, as compared to the prior year, primarily due to the receipt of a \$468 million order in the prior year period for AP1000 reactor coolant pumps and certain intellectual property rights. This decrease was partially offset by the timing of funding for pumps and generators with government customers of \$40 million.

SUPPLEMENTARY INFORMATION

The table below depicts sales by end market. End market sales help provide an enhanced understanding of our businesses and the markets in which we operate. The table has been included to supplement the discussion of our consolidated operating results.

Net Sales by End Market

| | Year Ended December 31, | | | Percent changes | |
|---|-------------------------|--------------|--------------|-----------------|---------------|
| | 2017 | 2016 | 2015 | 2017 vs. 2016 | 2016 vs. 2015 |
| <i>(In thousands, except percentages)</i> | | | | | |
| Defense markets: | | | | | |
| Aerospace | \$ 355,483 | \$ 296,314 | \$ 304,521 | 20% | (3%) |
| Ground | 94,216 | 84,288 | 85,722 | 12% | (2%) |
| Naval | 405,836 | 401,281 | 388,686 | 1% | 3% |
| Other | 21,321 | 11,721 | 8,340 | 82% | 41% |
| Total Defense | \$ 876,856 | \$ 793,604 | \$ 787,269 | 10% | 1% |
| Commercial markets: | | | | | |
| Aerospace | \$ 412,369 | \$ 397,327 | \$ 398,529 | 4% | —% |
| Power Generation | 423,981 | 408,509 | 436,396 | 4% | (6%) |
| General Industrial | 557,820 | 509,491 | 583,489 | 9% | (13%) |
| Total Commercial | \$ 1,394,170 | \$ 1,315,327 | \$ 1,418,414 | 6% | (7%) |
| Total Curtiss-Wright | \$ 2,271,026 | \$ 2,108,931 | \$ 2,205,683 | 8% | (4%) |

Note: Certain amounts in the prior year have been reclassified to conform to the current year presentation.

Year ended December 31, 2017 compared to year ended December 31, 2016

Defense sales increased \$83 million, or 10%, to \$877 million, as compared to the prior year period, primarily due to higher sales in the aerospace defense, ground defense, and other defense markets. The sales increase in the aerospace defense market was primarily due to the incremental impact of our TTC acquisition, which contributed \$47 million of sales. The aerospace defense market also benefited from increased demand of \$7 million for UAVs and higher production of \$8 million on the F-16 program, partially offset by declines in helicopter sales of \$5 million. Sales in the ground defense market increased primarily due to higher demand of \$8 million for our TDSS products on international ground defense platforms. Other defense sales increased primarily due to the incremental impact from our TTC acquisition, which contributed \$7 million of sales.

Commercial sales increased \$79 million, or 6%, to \$1,394 million, as compared to the prior year period, due to higher sales across all markets. In the commercial aerospace market, our TTC acquisition contributed \$8 million of incremental sales. Sales also benefited from increased demand for both our actuation and sensors and controls products. Within the power generation market, we generated higher production revenues of \$52 million on the AP1000 China Direct program, partially offset by lower aftermarket sales of \$24 million supporting domestic nuclear operating reactors and lower total production revenues of \$13 million on the AP1000 U.S. and China programs. In the general industrial market, we experienced higher demand for our industrial vehicle products which resulted in a sales increase of \$41 million.

Year ended December 31, 2016 compared to year ended December 31, 2015

Defense sales increased \$6 million, or 1%, to \$794 million, as compared to the prior year period, primarily due to higher sales in the naval defense market. Naval defense sales increased primarily due to the development on the Ohio replacement submarine program of \$16 million, higher production levels of \$5 million on the EMALS program, and higher sales of \$5 million supporting naval close-in weapon systems. These increases were partially offset by lower production of \$12 million on the Virginia-class submarine program and decreased aircraft carrier production of \$8 million due to the wind-down of the CVN-79 program. Lower sales in the aerospace defense market were primarily due to reduced foreign military sales.

Commercial sales decreased \$103 million, or 7%, to \$1,315 million, as compared to the prior year period, primarily due to lower sales in the general industrial and power generation markets of \$74 million and \$28 million, respectively. Lower sales in the general industrial market were primarily due to \$46 million of reduced sales for our severe-service industrial valves and lower sales for our industrial vehicle, medical mobility, and industrial automation products of \$7 million, \$8 million, and \$6 million, respectively. Lower sales in the power generation market were primarily driven by lower aftermarket sales of \$26 million supporting domestic and international nuclear operating reactors.

Liquidity and Capital Resources

Sources and Uses of Cash

We derive the majority of our operating cash inflow from receipts on the sale of goods and services and cash outflow for the procurement of materials and labor; cash flow is therefore subject to market fluctuations and conditions. Most of our long-term contracts allow for several billing points (progress or milestone) that provide us with cash receipts as costs are incurred throughout the project rather than upon contract completion, thereby reducing working capital requirements.

Consolidated Statement of Cash Flows

| <i>(In thousands)</i> | December 31, | | |
|--|--------------|-----------|-------------|
| | 2017 | 2016 | 2015 |
| Net cash provided by (used in): | | | |
| Operating activities | \$ 388,712 | \$423,197 | \$ 162,479 |
| Investing activities | (272,328) | (42,934) | (15,576) |
| Financing activities | (213,898) | (96,141) | (289,218) |
| Effect of exchange rates | 18,786 | (18,971) | (19,104) |
| Net increase (decrease) in cash and cash equivalents | \$ (78,728) | \$265,151 | \$(161,419) |

Year ended December 31, 2017 compared to year ended December 31, 2016

Operating Activities

Cash provided by operating activities decreased \$34 million to \$389 million during the year ended December 31, 2017, as compared to the prior year period. The decrease in cash provided by operating activities was primarily due to prior year collections related to the AP1000 China Direct program of \$102 million and a one-time \$20 million benefit in the prior year as a result of the interest rate swap termination. This was partially offset by the timing of advanced collections of \$48 million and higher cash earnings of \$36 million during the current period.

Investing Activities

Capital Expenditures

Our capital expenditures were \$53 million in 2017 as compared to \$47 million in 2016. This increase was primarily due to increased capital investment in our Defense and Power segments. For 2018, we anticipate capital expenditures of approximately \$50 to \$60 million.

Divestitures

No material divestitures took place during 2017 or 2016.

Acquisitions

In 2017, we acquired two businesses for a total purchase price of \$233 million. No acquisitions took place in 2016.

Future acquisitions will depend, in part, on the availability of financial resources at a cost of capital that meet our stringent criteria. As such, future acquisitions, if any, may be funded through the use of our cash and cash equivalents, through additional financing available under the credit agreement, or through new financing alternatives.

Financing Activities

Debt Issuances

There were no debt issuances on outstanding notes in 2017 or 2016. In 2017, we fully repaid the \$150 million 2005 Senior Notes that had matured. No principal payments on outstanding notes took place in 2016.

Revolving Credit Agreement

As of December 31, 2017, the Corporation had no borrowings outstanding under the 2012 Senior Unsecured Revolving Credit Agreement (the Credit Agreement or credit facility) and \$21 million in letters of credit supported by the credit facility. The unused credit available under the Credit Agreement as of December 31, 2017 was \$479 million, which could be borrowed in full without violating any of our debt covenants.

Repurchase of Common Stock

During 2017, the Company repurchased approximately 526,000 shares of its common stock for \$52 million. In 2016, the Company repurchased approximately 1,300,000 shares of its common stock for \$105 million.

Dividends

During 2017 and 2016, the Company made dividend payments of approximately \$25 million and \$23 million, respectively.

Year ended December 31, 2016 compared to year ended December 31, 2015

Operating Activities

Cash provided by operating activities increased \$261 million to \$423 million during the year ended December 31, 2016, as compared to the prior year period. The increase in cash provided by operating activities was primarily due to a prior period voluntary pension contribution of \$145 million and collections in 2016 related to the AP1000 China Direct program of \$102 million. Increases in income tax payments, net of refunds, of \$50 million during the current period were more than offset by improved collections due to working capital initiatives and a one-time \$20 million benefit as a result of the interest rate swap termination.

Investing Activities

Capital Expenditures

Our capital expenditures were \$47 million in 2016 as compared to \$36 million in 2015. Capital expenditures were greater in 2016, as compared to 2015, primarily due to increased capital investment in a facility expansion in our Commercial/Industrial segment.

Divestitures

No material divestitures took place during 2016. In 2015, we disposed of four businesses aggregating to cash proceeds of \$31 million.

Acquisitions

No acquisitions took place during 2016. In 2015, we acquired one business with a total purchase price of \$13 million.

Financing Activities

Debt Issuances

There were no debt issuances or significant principal payments on outstanding notes in 2016 or 2015.

Revolving Credit Agreement

As of December 31, 2016, the Corporation had no borrowings outstanding under the 2012 Senior Unsecured Revolving Credit Agreement (the Credit Agreement or credit facility) and \$47 million in letters of credit supported by the credit facility. The unused credit available under the Credit Agreement at December 31, 2016 was \$453 million, which could be borrowed in full without violating any of our debt covenants.

Repurchase of Common Stock

During 2016, the Corporation repurchased approximately 1,300,000 shares of its common stock for \$105 million. In 2015, the Corporation repurchased approximately 4,257,000 shares of its common stock for \$294 million.

Dividends

During 2016 and 2015, the Corporation made dividend payments of approximately \$23 million and \$24 million, respectively.

Capital Resources

Cash in Foreign Jurisdictions

Cash and cash equivalents as of December 31, 2017 were \$475 million, of which \$293 million were held by foreign subsidiaries. Our British subsidiaries held a substantial portion of the Company's cash and cash equivalents, totaling approximately \$122 million as of December 31, 2017. Cash and cash equivalents as of December 31, 2016 were \$554 million, of which \$198 million were held by foreign subsidiaries. Our British subsidiaries held a substantial portion of the Company's cash and cash equivalents, totaling approximately \$98 million as of December 31, 2016. The decrease in cash held by U.S. subsidiaries during 2017 as compared to 2016 was primarily due to the acquisition of two businesses during the current period, partially offset by lower share repurchases. There are no legal or economic restrictions on the ability of any of our subsidiaries to transfer funds, absent certain regulatory approvals in China, where approximately \$25 million of our foreign cash resides. Refer to Note 11 to the Consolidated Financial Statements for impacts on our foreign undistributed earnings due to the Tax Act.

Cash Utilization

Management continually evaluates cash utilization alternatives, including share repurchases, acquisitions, and increased dividends to determine the most beneficial use of available capital resources. We believe that our cash and cash equivalents, cash flow from operations, available borrowings under the credit facility, and ability to raise additional capital through the credit markets are sufficient to meet both the short-term and long-term capital needs of the organization, including the return of capital to shareholders through dividends and share repurchases and growing our business through acquisitions.

Debt Compliance

As of December 31, 2017, we were in compliance with all debt agreements and credit facility covenants, including our most restrictive covenant, which is our debt to capitalization ratio limit of 60%. As of December 31, 2017, we had the ability to incur total additional indebtedness of \$1.4 billion without violating our debt to capitalization covenant.

Future Commitments

Cash generated from operations should be adequate to meet our planned capital expenditures of approximately \$50 million to \$60 million and expected dividend payments of approximately \$26 million in 2018. There can be no assurance, however, that we will continue to generate cash from operations at the current level, or that these projections will remain constant throughout 2018. If cash generated from operations is not sufficient to support these operating requirements and investing activities, we may be required to reduce capital expenditures, borrow from our existing credit line, refinance a portion of our existing debt, or obtain additional financing. While all companies are subject to economic risk, we believe that our cash and cash equivalents, cash flow from operations, and available borrowings are sufficient to meet both the short-term and long-term capital needs of the organization.

In February 2018 and January 2015, we made discretionary pension contributions of \$50 million and \$145 million, respectively, to the Curtiss-Wright Pension Plan. For more information on our pension and other postretirement benefits plans, see Note 15 to the Consolidated Financial Statements.

In February 2018, we entered into an agreement to acquire the assets of the Dresser-Rand Government Business for \$212.5 million in cash. Refer to Note 21 to the Consolidated Financial Statements for more information.

The following table quantifies our significant future contractual obligations and commercial commitments as of December 31, 2017:

| <i>(In thousands)</i> | Total | 2018 | 2019 | 2020 | 2021 | 2022 | Thereafter |
|-----------------------------|--------------------|-----------------|-----------------|-----------------|------------------|-----------------|-------------------|
| Debt Principal Repayments | \$ 800,150 | \$ 150 | \$ — | \$ — | \$100,000 | \$ — | \$700,000 |
| Interest Payments on | | | | | | | |
| Fixed Rate Debt | 243,504 | 31,643 | 31,643 | 31,643 | 31,397 | 27,803 | 89,375 |
| Operating Leases | 180,095 | 28,284 | 24,378 | 21,733 | 17,577 | 14,253 | 73,870 |
| Tax Act - Transition | | | | | | | |
| Tax Payments ⁽¹⁾ | 23,700 | 1,896 | 1,896 | 1,896 | 1,896 | 1,896 | 14,220 |
| Build-to-suit Lease | 17,049 | 1,277 | 1,309 | 1,342 | 1,375 | 1,409 | 10,337 |
| Total | \$1,264,498 | \$63,250 | \$59,226 | \$56,614 | \$152,245 | \$45,361 | \$887,802 |

⁽¹⁾ Refer to Note 11 to the Consolidated Financial Statements for more information.

We do not have material purchase obligations. Most of our raw material purchase commitments are made directly pursuant to specific contract requirements.

We enter into standby letters of credit agreements and guarantees with financial institutions and customers primarily relating to future performance on certain contracts to provide products and services and to secure advance payments we have received from certain international customers. As of December 31, 2017, we had contingent liabilities on outstanding letters of credit due as follows:

| <i>(In thousands)</i> | Total | 2018 | 2019 | 2020 | 2021 | 2022 | Thereafter⁽¹⁾ |
|-----------------------|--------------|-------------|-------------|-------------|-------------|-------------|---------------------------------|
| Letters of Credit | \$21,342 | \$12,992 | \$4,116 | \$2,518 | \$1,047 | \$375 | \$294 |

⁽¹⁾ Amounts indicated as Thereafter are letters of credit that expire during the revolving credit agreement term but will automatically renew on the date of expiration. In addition, amounts exclude bank guarantees of approximately \$14.6 million.

Critical Accounting Estimates and Policies

Our consolidated financial statements and accompanying notes are prepared in accordance with accounting principles generally accepted in the United States of America. Preparing consolidated financial statements requires us to make estimates and assumptions that affect the reported amounts of assets, liabilities, revenues, and expenses. These estimates and assumptions are affected by the application of our accounting policies. Critical accounting policies are those that require application of management's most difficult, subjective, or complex judgments, often as a result of the need to make estimates about the effects of matters that are inherently uncertain and may change in subsequent periods. We believe that the following are some of the more critical judgment areas in the application of our accounting policies that affect our financial condition and results of operations:

Revenue Recognition

The realization of revenue refers to the timing of its recognition in our accounts and is generally considered realized or realizable and earned when the earnings process is substantially complete and all of the following criteria are met: 1) persuasive evidence of an arrangement exists; 2) delivery has occurred or services have been rendered; 3) our price to our customer is fixed or determinable; and 4) collectability is reasonably assured.

We determine the appropriate method by which we recognize revenue by analyzing the terms and conditions of each contract or arrangement entered into with our customers. Revenue is recognized on certain product sales, which represents approximately 57% of our 2017 total net sales, as production units are shipped and title and risk of loss have transferred. Revenue is recognized on service type contracts, which represents approximately 18% of our 2017 total net sales, as services are rendered. The majority of our service revenues are generated within our Commercial/Industrial segment. The significant estimates we make in recognizing revenue relate primarily to long-term contracts, which are generally accounted for using the cost-to-cost method of percentage-of-completion accounting and are associated with the design, development, and manufacture of highly engineered industrial products used in commercial and defense applications.

Percentage-of-completion accounting

Revenue recognized using the percentage-of-completion accounting represented approximately 25% of our total net sales in 2017. The typical length of our contracts, which predominantly utilize the cost-to-cost method of percentage-of-completion accounting, is 2-5 years. The cost-to-cost method recognizes revenue and profit as the contracts progress towards completion. Under the cost-to-cost method, sales and profits are recorded based on the ratio of costs incurred to an estimate of costs at completion.

Application of the cost-to-cost method of percentage-of-completion accounting requires the use of reasonable and dependable estimates of the future material, labor, and overhead costs that will be incurred and a disciplined cost estimating system in which all functions of the business are integrally involved. These estimates are determined based upon industry knowledge and experience of our engineers, project managers, and financial staff. These estimates are significant and reflect changes in cost and operating performance throughout the contract and could have a significant impact on our operating performance. Adjustments to original estimates for contract revenue, estimated costs at completion, and the estimated total profit are often required as work progresses throughout the contract and more information is obtained, even though the scope of work under the contract may not change. These changes are recorded on a cumulative basis in the period they are determined to be necessary.

Under the cost-to-cost method of percentage-of-completion accounting, provisions for estimated losses on uncompleted contracts are recognized in the period in which the likelihood of such losses are determined to be probable. However, costs may be deferred in anticipation of future contract sales if follow-on production orders are deemed probable. Amounts representing contract change orders are included in revenue only when they can be estimated reliably and their realization is reasonably assured.

In 2015, the Corporation recorded additional costs of \$11.5 million related to its long-term contract with WEC to deliver RCPs for the AP1000 nuclear power plants in China. The increase in costs was due to a change in estimate related to production modifications that are the result of engineering and endurance testing. During the twelve months ended December 31, 2017, 2016, and 2015, there were no other individual significant changes in estimated contract costs.

Multiple-element arrangements

From time to time, we may enter into multiple-element arrangements in which a customer may purchase a combination of goods, services, or rights to intellectual property. We follow the multiple element accounting guidance within ASC 605-25 for such arrangements which require: (1) determining the separate units of accounting; (2) determining whether the separate units of accounting have stand-alone value; and (3) measuring and allocating the arrangement consideration. We allocate the arrangement consideration in accordance with the selling price hierarchy which requires: (1) the use of vendor-specific objective evidence (VSOE), if available; (2) if VSOE is not available, the use of third-party evidence (TPE); and, if TPE is not available, (3) our best-estimate of selling price (BESP). During 2017 and 2016, the Corporation did not enter into any significant multiple-element arrangements. In 2015, approximately 1% of the Company's net sales were the result of the sale of certain intellectual property licensing rights within a multiple-element arrangement with China for AP1000 reactor coolant pumps (China Direct order). The Company had no further performance obligations with regards to the sale of these perpetual rights. The remainder of the contract, related to the production of sixteen RCPs, is being recognized using percentage-of-completion accounting through 2021.

Inventory

Inventory costs include materials, direct labor, purchasing, and manufacturing overhead costs, which are stated at the lower of cost or market, where market is limited to the net realizable value. We estimate the net realizable value of our inventories and establish reserves to reduce the carrying amount of these inventories to net realizable value, as necessary. We continually evaluate the adequacy of the inventory reserves by reviewing historical scrap rates, on-hand quantities as compared with historical and projected usage levels, and other anticipated contractual requirements. We generally hold reserved inventory for extended periods before scrapping and disposing of the reserved inventory, which contributes to a higher level of reserved inventory relative to the level of annual inventory write-offs.

We purchase materials for the manufacture of components for sale. The decision to purchase a set quantity of a particular item is influenced by several factors including: current and projected price, future estimated availability, existing and projected contracts to produce certain items, and the estimated needs for our businesses.

For certain of our long-term contracts, we utilize progress billings, which represent amounts billed to customers prior to the delivery of goods and services and are recorded as a reduction to inventory and receivables. Amounts are first applied to unbilled receivables and any remainder is then applied to inventory. Progress billings are generally based on costs incurred, including direct costs, overhead, and general and administrative costs.

Pension and Other Postretirement Benefits

In consultation with our actuaries, we determine the appropriate assumptions for use in determining the liability for future pension and other postretirement benefits. The most significant of these assumptions include the discount rates used to determine plan obligations, the expected return on plan assets, and the number of employees who will receive benefits, their tenure, their salary levels, and their projected mortality. Changes in these assumptions, if significant in future years, may have an effect on our pension and postretirement expense, associated pension and postretirement assets and liabilities, and our annual cash requirements to fund these plans.

The discount rate used to determine the plan benefit obligations as of December 31, 2017, and the annual periodic costs for 2018, was decreased from 4.10% to 3.63% for the Curtiss-Wright Pension Plan, and from 3.93% to 3.55% for the nonqualified benefit plan, to reflect current economic conditions. The rates reflect the hypothetical rates at which the projected benefit obligations could be effectively settled or paid out to participants on that date. We determine our discount rates for past service liabilities and service cost utilizing a select bond yield curve developed by our actuaries, by using the rates of return on high-quality, fixed-income corporate bonds available at the measurement date with maturities that match the plan's expected cash outflows for benefit payments. Interest cost is determined by applying the spot rate from the full yield curve to each anticipated benefit payment. The discount rate changes contributed to an increase in the benefit obligation of \$44 million in the CW plans.

The rate of compensation increase for base pay in the pension plans was unchanged at a weighted average of 3.4% based upon a graded scale of 4.9% to 2.9% that decrements as pay increases, which reflects the experience over past years and the Company's expectation of future salary increases. We also utilized the RP-2014 mortality tables published by the Society of Actuaries, and updated the projected mortality scale to MP-2017, which reflects a slower rate of future mortality improvements than the previous MP-2016 table utilized. This change contributed to a decrease in the benefit obligation of \$4 million.

The overall expected return on assets assumption is based primarily on the expectations of future performance. Expected future performance is determined by weighting the expected returns for each asset class by the plan's asset allocation. The expected returns are based on long-term capital market assumptions provided by our investment consultants. Based on a review of market trends, actual returns on plan assets, and other factors, the Company's expected long-term rate of return on plan assets remained at 8.00% as of December 31, 2017, which will be utilized for determining 2018 pension cost. Expected long-term rates of return of 8.00%, 8.25%, and 8.50% were used for determining 2017, 2016 and 2015 pension expense, respectively.

The timing and amount of future pension income or expense to be recognized each year is dependent on the demographics and expected compensation of the plan participants, the expected interest rates in effect in future years, inflation, and the actual and expected investment returns of the assets in the pension trust.

The funded status of the Curtiss-Wright Pension Plan decreased by \$5 million in 2017, primarily driven by a decrease in market interest rates as of December 31, 2017. This was partially offset by favorable asset experience due to strong market performance in 2017.

The following table reflects the impact of changes in selected assumptions used to determine the funded status of the Company's U.S. qualified and nonqualified pension plans as of December 31, 2017 (in thousands, except for percentage point change):

| Assumption | Percentage Point Change | Increase in Benefit Obligation | Increase in Expense |
|-------------------------------|-------------------------|--------------------------------|---------------------|
| Discount rate | (0.25)% | \$24,000 | \$2,500 |
| Rate of compensation increase | 0.25% | \$ 2,000 | \$ 500 |
| Expected return on assets | (0.25)% | — | \$1,600 |

See Note 15 to the Consolidated Financial Statements for further information on our pension and postretirement plans.

Purchase Accounting

We apply the purchase method of accounting to our acquisitions. Under this method, we allocate the cost of business acquisitions to the assets acquired and liabilities assumed based on their estimated fair values at the date of acquisition, commonly referred to as the purchase price allocation. As part of the purchase price allocations for our business acquisitions, identifiable intangible assets are recognized as assets apart from goodwill if they arise from contractual or other legal rights, or if they are capable of being separated or divided from the acquired business and sold, transferred, licensed, rented, or exchanged. The purchase price is allocated to the underlying tangible and intangible assets acquired and liabilities assumed based on their respective fair market values, with any excess recorded as goodwill. We determine the fair values of such assets and liabilities, generally in consultation with third-party valuation advisors. Such fair value assessments require significant judgments and estimates such as projected cash flows, discount rates, royalty rates, and remaining useful lives that can differ materially from actual results. The analysis, while substantially complete, is finalized no later than twelve months from the date of acquisition.

Goodwill

We have \$1.1 billion in goodwill as of December 31, 2017. Generally, the largest separately identifiable asset from the businesses that we acquire is the value of their assembled workforces, which includes the additional benefit received from management, administrative, marketing, business development, engineering, and technical employees of the acquired businesses. The success of our acquisitions, including the ability to retain existing business and to successfully compete for and win new business, is based on the additional benefit received from management, administrative, marketing, and business development, scientific, engineering, and technical skills and knowledge of our employees rather than on productive capital (plant and equipment, technology, and intellectual property). Therefore, since intangible assets for assembled workforces are part of goodwill, the substantial majority of the intangible assets for our acquired business acquisitions are recognized as goodwill.

We test for goodwill impairment annually, at the reporting unit level, in the fourth quarter, which coincides with the preparation of our strategic operating plan. Additionally, goodwill is tested for impairment when an event occurs or if circumstances change that would more likely than not reduce the fair value of a reporting unit below its carrying amount.

We perform either a quantitative or qualitative assessment to assess if the fair value of the respective reporting unit exceeds its carrying value. The qualitative goodwill impairment assessment requires evaluating factors to determine whether it is more likely than not that the fair value of a reporting unit is less than its carrying amount. As part of our goodwill qualitative assessment process for each reporting unit, when utilized, we evaluate various factors that are specific to the reporting unit as well as industry and macroeconomic factors in order to determine whether it is reasonably likely to have a material impact on the fair value of our reporting units. Examples of the factors that are considered include the results of the most recent impairment test, current and long-range forecasts, and changes in the strategic outlook or organizational structure of the reporting units. The long-range financial forecasts of the reporting units are compared to the forecasts used in the prior year analysis to determine if management expectations for the business have changed.

Actual results may differ from those estimates. When performing the quantitative assessment to calculate the fair value of a reporting unit, we consider both comparative market multiples as well as estimated discounted cash flows for the reporting unit. The significant estimates and assumptions include, but are not limited to, revenue growth rates, operating margins, and future economic and market conditions. The discount rates are based upon the reporting unit's weighted average cost of capital. As a supplement, we conduct additional sensitivity analysis to assess the risk for potential impairment based upon changes in the key assumptions such as the discount rate, expected long-term growth rate, and cash flow projections. Based upon the completion of our annual test, which included qualitative assessments, we determined that there was no impairment of goodwill and that all reporting units' estimated fair values were substantially in excess of their carrying amounts.

Other Intangible Assets

Other intangible assets are generally the result of acquisitions and consist primarily of purchased technology, customer related intangibles, and trademarks. Intangible assets are recorded at their fair values as determined through purchase accounting, based on estimates and judgments regarding expectations for the estimated future after-tax earnings and cash flows arising from follow-on sales. Definite-lived intangible assets are amortized on a straight-line basis over their estimated useful lives, which generally range from 1 to 20 years. Customer-related intangibles primarily consist of customer relationships, which reflect the value of the benefit derived from the incremental revenue and related cash flows as a direct result of the customer relationship. We review the recoverability of all intangible assets, including the related useful lives, whenever events or changes in circumstances indicate that the carrying amount might not be recoverable. We would record any impairment in the reporting period in which it has been identified.

Item 7A. Quantitative and Qualitative Disclosures about Market Risk.

We are exposed to certain market risks from changes in interest rates and foreign currency exchange rates as a result of our global operating and financing activities. We seek to minimize any material risks from foreign currency exchange rate fluctuations through our normal operating and financing activities and, when deemed appropriate, through the use of derivative financial instruments. We used forward foreign currency contracts to manage our currency rate exposures during the year ended December 31, 2017, and, in order to manage our interest rate risk, we may, from time to time, enter into interest rate swaps to balance the ratio of fixed to floating rate debt. We do not use such instruments for trading or other speculative purposes. Information regarding our accounting policy on financial instruments is contained in Note 1 to the Consolidated Financial Statements.

Interest Rates

The market risk for a change in interest rates relates primarily to our debt obligations. Our fixed rate interest exposure, without consideration of our interest rate swap agreements, was 100% as of December 31, 2017 and December 31, 2016. In order to manage our interest rate exposure, from time to time, we enter into interest rate swap agreements to manage our mix of fixed-rate and variable-rate debt. As of December 31, 2017, a change in interest rates of 1% would not have a material impact on the consolidated interest expense. In 2016, we terminated our previous interest rate swap agreements and did not enter into any interest rate swap agreements. Information regarding our Senior Notes and Revolving Credit Agreement is contained in Note 12 to the Consolidated Financial Statements.

Foreign Currency Exchange Rates

Although the majority of our business is transacted in U.S. dollars, we do have market risk exposure to changes in foreign currency exchange rates, primarily as it relates to the value of the U.S. dollar versus the British Pound, Canadian dollar, and Euro. Any significant change against the U.S. dollar in the value of the currencies of those countries in which we do business could have an effect on our business, financial

condition, and results of operations. If foreign exchange rates were to collectively weaken or strengthen against the U.S. dollar by 10%, net earnings would have been reduced or increased, respectively, by approximately \$12 million as it relates exclusively to foreign currency exchange rate exposures.

Financial instruments expose us to counter-party credit risk for non-performance and to market risk for changes in interest and foreign currency rates. We manage exposure to counter-party credit risk through specific minimum credit standards, diversification of counter-parties, and procedures to monitor concentrations of credit risk. We monitor the impact of market risk on the fair value and cash flows of our investments by investing primarily in investment grade interest-bearing securities, which have short-term maturities. We attempt to minimize possible changes in interest and currency exchange rates to amounts that are not material to our consolidated results of operations and cash flows.

Item 8. Financial Statements and Supplementary Data.

CONSOLIDATED STATEMENTS OF EARNINGS

| | For the years ended December 31, | | |
|---|----------------------------------|-------------------|-------------------|
| <i>(In thousands, except per share data)</i> | 2017 | 2016 | 2015 |
| Net sales | | | |
| Product sales | \$ 1,854,216 | \$ 1,714,358 | \$ 1,796,802 |
| Service sales | 416,810 | 394,573 | 408,881 |
| Total net sales | <u>2,271,026</u> | <u>2,108,931</u> | <u>2,205,683</u> |
| Cost of sales | | | |
| Cost of product sales | 1,184,358 | 1,100,287 | 1,156,596 |
| Cost of service sales | 268,073 | 258,161 | 265,832 |
| Total cost of sales | <u>1,452,431</u> | <u>1,358,448</u> | <u>1,422,428</u> |
| Gross profit | 818,595 | 750,483 | 783,255 |
| Research and development expenses | 60,308 | 58,592 | 60,837 |
| Selling expenses | 120,002 | 111,228 | 121,482 |
| General and administrative expenses | <u>298,542</u> | <u>272,565</u> | <u>290,319</u> |
| Operating income | 339,743 | 308,098 | 310,617 |
| Interest expense | 41,471 | 41,248 | 36,038 |
| Other income, net | <u>1,347</u> | <u>1,111</u> | <u>615</u> |
| Earnings before income taxes | 299,619 | 267,961 | 275,194 |
| Provision for income taxes | <u>(84,728)</u> | <u>(78,579)</u> | <u>(82,946)</u> |
| Earnings from continuing operations | <u>214,891</u> | <u>189,382</u> | <u>192,248</u> |
| Loss from discontinued operations, net of taxes | <u>—</u> | <u>(2,053)</u> | <u>(46,787)</u> |
| Net earnings | <u>\$ 214,891</u> | <u>\$ 187,329</u> | <u>\$ 145,461</u> |
| Basic earnings per share: | | | |
| Earnings from continuing operations | \$ 4.86 | \$ 4.27 | \$ 4.12 |
| Loss from discontinued operations | <u>—</u> | <u>(0.05)</u> | <u>(1.00)</u> |
| Total | <u>\$ 4.86</u> | <u>\$ 4.22</u> | <u>\$ 3.12</u> |
| Diluted earnings per share: | | | |
| Earnings from continuing operations | \$ 4.80 | \$ 4.20 | \$ 4.04 |
| Loss from discontinued operations | <u>—</u> | <u>(0.05)</u> | <u>(0.99)</u> |
| Total | <u>\$ 4.80</u> | <u>\$ 4.15</u> | <u>\$ 3.05</u> |
| Dividends per share | <u>\$ 0.56</u> | <u>\$ 0.52</u> | <u>\$ 0.52</u> |
| Weighted average shares outstanding: | | | |
| Basic | 44,182 | 44,389 | 46,624 |
| Diluted | 44,761 | 45,045 | 47,616 |

See notes to consolidated financial statements

CONSOLIDATED STATEMENTS OF COMPREHENSIVE INCOME

| <i>(In thousands)</i> | For the years ended December 31, | | |
|---|----------------------------------|-------------------|------------------|
| | 2017 | 2016 | 2015 |
| Net earnings | \$ 214,891 | \$ 187,329 | \$ 145,461 |
| Other comprehensive income | | | |
| Foreign currency translation, net of tax ⁽¹⁾ | 77,942 | (64,840) | (87,527) |
| Pension and postretirement adjustments, net of tax ⁽²⁾ | (3,026) | (988) | (9,990) |
| Other comprehensive income (loss), net of tax | 74,916 | (65,828) | (97,517) |
| Comprehensive income | <u>\$ 289,807</u> | <u>\$ 121,501</u> | <u>\$ 47,944</u> |

⁽¹⁾ The tax benefit (expense) included in other comprehensive income for foreign currency translation adjustments for 2017, 2016, and 2015 were (\$1.9) million, \$1.7 million, and \$2.7 million, respectively.

⁽²⁾ The tax benefit (expense) included in other comprehensive income for pension and postretirement adjustments for 2017, 2016, and 2015 were \$2.8 million, (\$1.7) million, and \$9.5 million, respectively.

See notes to consolidated financial statements

CONSOLIDATED BALANCE SHEETS

| <i>(In thousands, except share data)</i> | As of December 31, | |
|---|---------------------------|---------------------|
| | 2017 | 2016 |
| ASSETS | | |
| Current assets: | | |
| Cash and cash equivalents | \$ 475,120 | \$ 553,848 |
| Receivables, net | 494,923 | 463,062 |
| Inventories, net | 378,866 | 366,974 |
| Other current assets | 52,951 | 30,927 |
| Total current assets | 1,401,860 | 1,414,811 |
| Property, plant, and equipment, net | 390,235 | 388,903 |
| Goodwill | 1,096,329 | 951,057 |
| Other intangible assets, net | 329,668 | 271,461 |
| Other assets | 18,229 | 11,549 |
| Total assets | <u>\$3,236,321</u> | <u>\$ 3,037,781</u> |
| LIABILITIES | | |
| Current liabilities: | | |
| Current portion of long-term and short-term debt | \$ 150 | \$ 150,668 |
| Accounts payable | 185,176 | 177,911 |
| Accrued expenses | 150,406 | 130,239 |
| Income taxes payable | 4,564 | 18,274 |
| Deferred revenue | 214,891 | 170,143 |
| Other current liabilities | 35,810 | 28,027 |
| Total current liabilities | 590,997 | 675,262 |
| Long-term debt | 813,989 | 815,630 |
| Deferred tax liabilities, net | 49,360 | 49,722 |
| Accrued pension and other postretirement benefit costs | 121,043 | 107,151 |
| Long-term portion of environmental reserves | 14,546 | 14,024 |
| Other liabilities | 118,586 | 84,801 |
| Total liabilities | 1,708,521 | 1,746,590 |
| Contingencies and Commitments (Notes 12, 16 and 18) | | |
| STOCKHOLDERS' EQUITY | | |
| Common stock, \$1 par value, 100,000,000 shares authorized as of December 31, 2017 and December 31, 2016; 49,187,378 shares issued as of December 31, 2017 and December 31, 2016; outstanding shares were 44,123,519 as of December 31, 2017 and 44,181,050 as of December 31, 2016 | | |
| | 49,187 | 49,187 |
| Additional paid in capital | 120,609 | 129,483 |
| Retained earnings | 1,944,324 | 1,754,907 |
| Accumulated other comprehensive loss | (216,840) | (291,756) |
| Common treasury stock, at cost (5,063,859 shares as of December 31, 2017 and 5,006,328 shares as of December 31, 2016) | (369,480) | (350,630) |
| Total stockholders' equity | 1,527,800 | 1,291,191 |
| Total liabilities and stockholders' equity | <u>\$3,236,321</u> | <u>\$ 3,037,781</u> |

See notes to consolidated financial statements

CONSOLIDATED STATEMENTS OF CASH FLOWS

| | For the years ended December 31, | | |
|--|----------------------------------|-------------------|-------------------|
| (In thousands) | 2017 | 2016 | 2015 |
| Cash flows from operating activities: | | | |
| Net earnings | \$ 214,891 | \$ 187,329 | \$ 145,461 |
| Adjustments to reconcile net earnings to net cash provided by operating activities: | | | |
| Depreciation and amortization | 99,995 | 96,008 | 100,810 |
| (Gain) loss on sale of businesses | (875) | (845) | 16,991 |
| (Gain) loss on fixed asset disposals | 29 | (2,069) | (945) |
| Deferred income taxes | (5,782) | 1,224 | 63,535 |
| Share-based compensation | 11,572 | 9,478 | 9,473 |
| Impairment of assets held for sale | — | — | 40,813 |
| Changes in operating assets and liabilities, net of businesses acquired and disposed of: | | | |
| Receivables, net | (16,388) | 91,692 | (77,106) |
| Inventories, net | 19,711 | 4,391 | (4,039) |
| Progress payments | (774) | 2,583 | 3,680 |
| Accounts payable and accrued expenses | 4,323 | 4,125 | (447) |
| Deferred revenue | 36,898 | (11,084) | 4,839 |
| Income taxes | (5,479) | 11,797 | (7,436) |
| Net pension and postretirement liabilities | 3,481 | 3,405 | (139,610) |
| Termination of interest rate swap | — | 20,405 | — |
| Other liabilities | 25,686 | 11,474 | (5,410) |
| Other | 1,424 | (6,716) | 11,870 |
| Net cash provided by operating activities | <u>388,712</u> | <u>423,197</u> | <u>162,479</u> |
| Cash flows from investing activities: | | | |
| Proceeds from sales and disposals of long-lived assets | 6,769 | 3,674 | 2,277 |
| Proceeds from divestitures | 6,973 | 1,027 | 31,344 |
| Additions to property, plant, and equipment | (52,705) | (46,776) | (35,512) |
| Acquisition of businesses, net of cash acquired | (232,630) | (295) | (13,228) |
| Additional consideration paid on prior year acquisitions | (735) | (564) | (457) |
| Net cash used for investing activities | <u>(272,328)</u> | <u>(42,934)</u> | <u>(15,576)</u> |
| Cash flows from financing activities: | | | |
| Borrowings under revolving credit facilities | 7,658 | 7,839 | 70,324 |
| Payment of revolving credit facilities | (8,176) | (8,430) | (70,134) |
| Principal payments on debt | (150,000) | — | (8,400) |
| Repurchases of company stock | (52,127) | (105,249) | (294,130) |
| Proceeds from share-based compensation plans | 14,179 | 22,300 | 28,706 |
| Dividends paid | (24,740) | (23,067) | (24,122) |
| Other | (692) | (635) | (581) |
| Excess tax benefits from share-based compensation | — | 11,101 | 9,119 |
| Net cash used for financing activities | <u>(213,898)</u> | <u>(96,141)</u> | <u>(289,218)</u> |
| Effect of exchange-rate changes on cash | <u>18,786</u> | <u>(18,971)</u> | <u>(19,104)</u> |
| Net increase (decrease) in cash and cash equivalents | (78,728) | 265,151 | (161,419) |
| Cash and cash equivalents at beginning of year | <u>553,848</u> | <u>288,697</u> | <u>450,116</u> |
| Cash and cash equivalents at end of year | <u>\$ 475,120</u> | <u>\$ 553,848</u> | <u>\$ 288,697</u> |
| Supplemental disclosure of non-cash activities: | | | |
| Capital expenditures incurred but not yet paid | 976 | 2,512 | 2,108 |

See notes to consolidated financial statements

CONSOLIDATED STATEMENTS OF STOCKHOLDERS' EQUITY
(In thousands)

| | Common Stock | Additional Paid in Capital | Retained Earnings | Accumulated Other Comprehensive Income (Loss) | Treasury Stock |
|--|-----------------|----------------------------------|----------------------|--|--------------------|
| January 1, 2015 | \$49,190 | \$158,043 | \$1,469,306 | \$(128,411) | \$ (69,695) |
| Net earnings | — | — | 145,461 | — | — |
| Other comprehensive loss, net of tax | — | — | — | (97,517) | — |
| Dividends paid | — | — | (24,122) | — | — |
| Restricted stock, net of tax | — | (10,303) | — | — | 13,734 |
| Stock options exercised, net of tax | — | (11,349) | — | — | 45,743 |
| Other | — | (647) | — | — | 647 |
| Share-based compensation | — | 9,179 | — | — | 294 |
| Repurchase of common stock | — | — | — | — | (294,130) |
| December 31, 2015 | \$49,190 | \$144,923 | \$1,590,645 | \$(225,928) | \$(303,407) |
| Net earnings | — | — | 187,329 | — | — |
| Other comprehensive loss, net of tax | — | — | — | (65,828) | — |
| Dividends paid | — | — | (23,067) | — | — |
| Restricted stock, net of tax | — | (12,086) | — | — | 17,275 |
| Stock options exercised, net of tax | — | (11,271) | — | — | 39,483 |
| Other | (3) | (1,104) | — | — | 811 |
| Share-based compensation | — | 9,021 | — | — | 457 |
| Repurchase of common stock | — | — | — | — | (105,249) |
| December 31, 2016 | \$49,187 | \$129,483 | \$1,754,907 | \$(291,756) | \$(350,630) |
| Net earnings | — | — | 214,891 | — | — |
| Other comprehensive income, net of tax | — | — | — | 74,916 | — |
| Dividends paid | — | — | (24,740) | — | — |
| Restricted stock, net of tax | — | (12,104) | — | — | 12,105 |
| Stock options exercised, net of tax | — | (5,724) | — | — | 19,902 |
| Other | — | (2,237) | (734) | — | 889 |
| Share-based compensation | — | 11,191 | — | — | 381 |
| Repurchase of common stock | — | — | — | — | (52,127) |
| December 31, 2017 | <u>\$49,187</u> | <u>\$120,609</u> | <u>\$1,944,324</u> | <u>\$(216,840)</u> | <u>\$(369,480)</u> |

See notes to consolidated financial statements

NOTES TO CONSOLIDATED FINANCIAL STATEMENTS

1. SUMMARY OF SIGNIFICANT ACCOUNTING POLICIES

Nature of Operations

Curtiss-Wright Corporation and its subsidiaries (the Corporation or the Company) is a global, diversified manufacturing and service company that designs, manufactures, and overhauls precision components and provides highly engineered products and services to the aerospace, defense, general industrial, and power generation markets.

Principles of Consolidation

The consolidated financial statements include the accounts of the Corporation and its majority-owned subsidiaries. All intercompany transactions and accounts have been eliminated.

Use of Estimates

The financial statements of the Corporation have been prepared in conformity with accounting principles generally accepted in the United States of America (U.S. GAAP), which requires management to make estimates and judgments that affect the reported amount of assets, liabilities, revenue, and expenses and disclosure of contingent assets and liabilities in the accompanying financial statements. The most significant of these estimates includes the estimate of costs to complete long-term contracts under the percentage-of-completion accounting methods, the estimate of useful lives for property, plant, and equipment, cash flow estimates used for testing the recoverability of assets, pension plan and postretirement obligation assumptions, estimates for inventory obsolescence, estimates for the valuation and useful lives of intangible assets and legal reserves. Actual results may differ from these estimates.

Revenue Recognition

The realization of revenue refers to the timing of its recognition in the accounts of the Corporation and is generally considered realized or realizable and earned when the earnings process is substantially complete and all of the following criteria are met: 1) persuasive evidence of an arrangement exists; 2) delivery has occurred or services have been rendered; 3) the Corporation's price to its customer is fixed or determinable; and 4) collectability is reasonably assured.

The Corporation determines the appropriate method by which it recognizes revenue by analyzing the terms and conditions of each contract or arrangement entered into with its customers. Revenue is recognized on product sales as production units are shipped and title and risk of loss have transferred. Revenue is recognized on service type contracts as services are rendered. The significant estimates made in recognizing revenue are primarily for long-term contracts generally accounted for using the cost-to-cost method of percentage of completion accounting that are associated with the design, development and manufacture of highly engineered industrial products used in commercial and defense applications. Under the cost-to-cost percentage-of-completion method of accounting, profits are recorded pro rata, based upon current estimates of direct and indirect costs to complete such contracts. Changes in estimates of contract sales, costs, and profits are recognized using the cumulative catch-up method of accounting. This method recognizes in the current period the cumulative effect of the changes on current and prior periods. The effect of the changes on future periods of contract performance is recognized as if the revised estimate had been the original estimate. A significant change in an estimate on one or more contracts could have a material effect on the Corporation's consolidated financial position, results of operations, or cash flows. In 2015, the Corporation recorded additional costs of \$11.5 million related to its long-term contract with Westinghouse Electric Company (WEC) to deliver reactor coolant pumps (RCPs) for the AP1000 nuclear power plants in China. The increase in costs is due to a change in estimate related to production modifications that are the result of engineering and endurance testing. There were no other individual significant changes in estimated contract costs at completion during 2017, 2016, or 2015.

Losses on contracts are provided for in the period in which the losses become determinable and the excess of billings over cost and estimated earnings on long-term contracts is included in deferred revenue.

From time to time, the Corporation may enter into multiple-element arrangements in which a customer may purchase a combination of goods, services, or rights to intellectual property. The Corporation follows the multiple element accounting guidance within ASC 605-25 for such arrangements which require: (1) determining the separate units of accounting; (2) determining whether the separate units of accounting have stand-alone value; and (3) measuring and allocating the arrangement consideration. Arrangement consideration is allocated in accordance with the selling price hierarchy which requires: (1) the use of vendor-specific objective evidence (VSOE), if available (2) if VSOE is not available, the use of third-party evidence (TPE), and if TPE is not available (3) our best-estimate of selling price (BESP). Approximately 1% of the Company's 2015 net sales were the result of the sale of certain intellectual property licensing rights within a multiple-element arrangement with China for AP1000 reactor coolant pumps (China Direct order). The Company had no further performance obligations with regards to the sale of these perpetual rights. The remainder of the contract, related to the production of sixteen RCPs, is being recognized using percentage-of-completion accounting through 2021.

Cash and Cash Equivalents

Cash equivalents consist of money market funds and commercial paper that are readily convertible into cash, all with original maturity dates of three months or less.

Inventory

Inventories are stated at lower of cost or market. Production costs are comprised of direct material and labor and applicable manufacturing overhead.

Progress Payments

Certain long-term contracts provide for interim billings as costs are incurred on the respective contracts. Pursuant to contract provisions, agencies of the U.S. Government and other customers are granted title or a secured interest for materials and work-in-process included in inventory to the extent progress payments are received. Accordingly, these receipts have been reported as a reduction of unbilled receivables and inventories, as presented in Notes 4 and 5 to the Consolidated Financial Statements.

Property, Plant, and Equipment

Property, plant, and equipment are carried at cost less accumulated depreciation. Major renewals and betterments are capitalized, while maintenance and repairs that do not improve or extend the life of the asset are expensed in the period that they are incurred. Depreciation is computed using the straight-line method based over the estimated useful lives of the respective assets.

Average useful lives for property, plant, and equipment are as follows:

| | |
|---------------------------------|---------------|
| Buildings and improvements | 5 to 40 years |
| Machinery, equipment, and other | 3 to 15 years |

Intangible Assets

Intangible assets are generally the result of acquisitions and consist primarily of purchased technology, customer related intangibles, trademarks, and technology licenses. Intangible assets are amortized on a straight-line basis over their estimated useful lives, which range from 1 to 20 years. See Note 8 to the Consolidated Financial Statements for further information on other intangible assets.

Impairment of Long-Lived Assets

The Corporation reviews the recoverability of all long-lived assets, including the related useful lives, whenever events or changes in circumstances indicate that the carrying amount of a long-lived asset might not be recoverable. If required, the Corporation compares the estimated fair value determined by

either the undiscounted future net cash flows or appraised value to the related asset's carrying value to determine whether there has been an impairment. If an asset is considered impaired, the asset is written down to fair value in the period in which the impairment becomes known. The Corporation recognized no significant impairment charges on assets held in use during the years ended December 31, 2017, 2016, and 2015. For impairment charges on assets held for sale, see Note 2 to the Consolidated Financial Statements.

Goodwill

Goodwill results from business acquisitions. The Corporation accounts for business acquisitions by allocating the purchase price to the tangible and intangible assets acquired and liabilities assumed. Assets acquired and liabilities assumed are recorded at their fair values, and the excess of the purchase price over the amounts allocated is recorded as goodwill. The recoverability of goodwill is subject to an annual impairment test or whenever an event occurs or circumstances change that would more likely than not result in an impairment. The impairment test is based on the estimated fair value of the underlying businesses. The Corporation's goodwill impairment test is performed annually in the fourth quarter of each year. See Note 7 to the Consolidated Financial Statements for further information on goodwill.

Fair Value of Financial Instruments

Accounting guidance requires certain disclosures regarding the fair value of financial instruments. Due to the short maturities of cash and cash equivalents, accounts receivable, accounts payable, and accrued expenses, the net book value of these financial instruments is deemed to approximate fair value. See Notes 9 and 12 to the Consolidated Financial Statements for further information on the Corporation's financial instruments.

Research and Development

The Corporation funds research and development programs for commercial products and independent research and development and bid and proposal work related to government contracts. Development costs include engineering and field support for new customer requirements. Corporation-sponsored research and development costs are expensed as incurred.

Research and development costs associated with customer-sponsored programs are capitalized to inventory and are recorded in cost of sales when products are delivered or services performed. Funds received under shared development contracts are a reduction of the total development expenditures under the shared contract and are shown net as research and development costs.

Accounting for Share-Based Payments

The Corporation follows the fair value based method of accounting for share-based employee compensation, which requires the Corporation to expense all share-based employee compensation. Share-based employee compensation is a non-cash expense since the Corporation settles these obligations by issuing the shares of Curtiss-Wright Corporation instead of settling such obligations with cash payments.

Compensation expense for non-qualified share options, performance shares, and time-based restricted stock is recognized over the requisite service period for the entire award based on the grant date fair value.

Income Taxes

The Corporation accounts for income taxes using the asset and liability method. Under the asset and liability method, deferred tax assets and liabilities are recognized for future tax consequences attributable to differences between the financial statement carrying amounts of existing assets and liabilities and their respective tax bases. The effect on deferred tax assets and liabilities of a change in tax laws is recognized in the results of operations in the period the new laws are enacted. A valuation allowance is recorded to reduce the carrying amounts of deferred tax assets unless it is more likely than not that such assets will be realized.

The Corporation records amounts related to uncertain income tax positions by 1) prescribing a minimum recognition threshold a tax position is required to meet before being recognized in the financial statements and 2) the measurement of the income tax benefits recognized from such positions. The Corporation's accounting policy is to classify uncertain income tax positions that are not expected to be resolved in one year as a non-current income tax liability and to classify interest and penalties as a component of Interest expense and General and administrative expenses, respectively. See Note 11 to the Consolidated Financial Statements for further information.

Foreign Currency

For operations outside the United States of America that prepare financial statements in currencies other than the U.S. dollar, the Corporation translates assets and liabilities at period-end exchange rates and income statement amounts using weighted-average exchange rates for the period. The cumulative effect of translation adjustments is presented as a component of accumulated other comprehensive income (loss) within stockholders' equity. This balance is affected by foreign currency exchange rate fluctuations and by the acquisition of foreign entities. (Gains) and losses from foreign currency transactions are included in General and administrative expenses in the Consolidated Statements of Earnings, which amounted to \$5.4 million, \$(8.9) million, and (\$8.3) million for the years ended December 31, 2017, 2016, and 2015, respectively.

Derivatives

Forward Foreign Exchange and Currency Option Contracts

The Corporation uses financial instruments, such as forward exchange and currency option contracts, to hedge a portion of existing and anticipated foreign currency denominated transactions. The purpose of the Corporation's foreign currency risk management program is to reduce volatility in earnings caused by exchange rate fluctuations. All of the derivative financial instruments are recorded at fair value based upon quoted market prices for comparable instruments, with the gain or loss on these transactions recorded into earnings in the period in which they occur. These (gains) and losses are classified as General and administrative expenses in the Consolidated Statements of Earnings and amounted to (\$0.3) million, \$11.5 million, and \$11.0 million for the years ended December 31, 2017, 2016, and 2015, respectively. The Corporation does not use derivative financial instruments for trading or speculative purposes.

Interest Rate Risks and Related Strategies

The Corporation's primary interest rate exposure results from changes in U.S. dollar interest rates. The Corporation's policy is to manage interest cost using a mix of fixed and variable rate debt. The Corporation periodically uses interest rate swaps to manage such exposures. Under these interest rate swaps, the Corporation exchanges, at specified intervals, the difference between fixed and floating interest amounts calculated by reference to an agreed-upon notional principal amount.

For interest rate swaps designated as fair value hedges (i.e., hedges against the exposure to changes in the fair value of an asset or a liability or an identified portion thereof that is attributable to a particular risk), changes in the fair value of the interest rate swaps offset changes in the fair value of the fixed rate debt due to changes in market interest rates.

Recently Issued Accounting Standards

Recent accounting pronouncements adopted

| Standard | Description | Effect on the consolidated financial statements |
|--|---|---|
| ASU 2017-04 Simplifying the Test for Goodwill Impairment | In January 2017, the FASB issued ASU 2017-04, Simplifying the Test for Goodwill Impairment, which simplifies the measurement of goodwill impairment testing by removing step two. This guidance was early adopted effective January 1, 2017 and will be applied prospectively. | The adoption of this standard did not have a financial impact on the Consolidated Financial Statements. |
| Date of adoption: January 1, 2017 | | |
| ASU 2016-09 Improvements to Employee Share-Based Payment Accounting | In March 2016, the FASB issued ASU 2016-09, Improvements to Employee Share-Based Payment Accounting, which simplifies several aspects of the accounting for employee share-based payment transactions for both public and nonpublic entities, including the accounting for income taxes and forfeitures. Excess tax benefits previously reported as cash flows from financing activities in the Consolidated Financial Statements are now required to be reported as operating activities. The Company adopted this guidance effective January 1, 2017. | The Corporation recorded an income tax benefit of approximately \$8 million within the provision for income taxes for the year ended December 31, 2017, related to the excess tax benefit on stock options and performance share units. Prior to adoption, this amount would have been recorded as an increase to additional paid-in capital. The Corporation elected to account for forfeitures as they occur, which did not have a material impact on its Consolidated Financial Statements. |
| Date of adoption: January 1, 2017 | | |

Recent accounting pronouncements to be adopted

| Standard | Description | Effect on the consolidated financial statements |
|---|--|---|
| ASU 2014-09 Revenue from Contracts with Customers | <p>In May 2014, the FASB issued a comprehensive new revenue recognition standard which will supersede previous existing revenue recognition guidance. The standard creates a five-step model for revenue recognition that requires companies to exercise judgment when considering contract terms and relevant facts and circumstances. The five-step model includes (1) identifying the contract, (2) identifying the separate performance obligations in the contract, (3) determining the transaction price, (4) allocating the transaction price to the separate performance obligations and (5) recognizing revenue when each performance obligation has been satisfied. The standard also requires expanded disclosures surrounding revenue recognition. The standard is effective for fiscal periods beginning after December 15, 2017 and allows for either full retrospective or modified retrospective adoption.</p> | <p>The Corporation will apply the modified retrospective approach upon adoption as of January 1, 2018. The Corporation has completed its assessment and has identified certain contracts, primarily in the Defense and Power segments, which will be required to transition from a “point in time” model to an “over-time” model as they meet one or more of the mandatory criteria established under the new standard. The transition adjustment as of January 1, 2018 will primarily include the following: a) U.S. Government and commercial contracts where promised goods do not have alternative use and the Corporation has an enforceable right to payment for performance completed to date; b) repair and overhaul services performed on customer-owned goods; and c) Defense-related contracts where the Corporation uses customer-owned materials in production. The cumulative effect expected to be recognized upon adoption is a reduction to retained earnings of approximately \$2 million, net of tax, with a corresponding increase in unbilled receivables of \$18 million and decrease in inventory of \$24 million.</p> |
| <p>Date of adoption: January 1, 2018</p> | | |
| ASU 2016-02 Leases | <p>In February 2016, the FASB issued final guidance that will require lessees to put most leases on their balance sheets but recognize expenses on their income statements in a manner similar to today’s accounting.</p> | <p>The Corporation is currently evaluating the impact of the adoption of this standard on its Consolidated Financial Statements.</p> |
| <p>Date of adoption: January 1, 2019</p> | | |

| Standard | Description | Effect on the consolidated financial statements |
|---|---|---|
| ASU 2017-01 Clarifying the Definition of a Business | In January 2017, the FASB issued ASU 2017-01, which clarifies the definition of a business to assist entities with evaluating whether transactions should be accounted for as acquisitions or disposals of assets or businesses. The standard introduces a screen for determining when assets acquired are not a business and clarifies that a business must include, at a minimum, an input and a substantive process that contribute to an output. The standard is effective for fiscal years beginning after December 15, 2017, and interim periods within those fiscal years. | The Corporation does not expect the adoption of this standard to have a material impact on its Consolidated Financial Statements. |

Date of adoption:
January 1, 2018

| | | |
|--|--|---|
| ASU 2017-07 Improving the Presentation of Net Periodic Pension Cost and Net Periodic Postretirement Benefit Cost | In March 2017, the FASB issued final guidance that requires the service cost component of net periodic benefit costs from defined benefit and other postretirement benefit plans be included in the same Consolidated Statement of Earnings captions as other compensation costs arising from services rendered by the covered employees during the period. The other components of net benefit cost will be presented in the Statement of Earnings separately from service costs. This standard is effective for fiscal years beginning after December 15, 2017. Following adoption, only service costs will be eligible for capitalization into manufactured inventories. The amendments of this standard should be applied retrospectively for the presentation of the service cost component and the other components of net periodic benefit costs. | The Corporation does not expect the adoption of this standard to have a material impact on its Consolidated Financial Statements. Any decrease in operating income due to presentation of interest cost, expected return on plan assets, amortization of prior service cost, and net actuarial gain/loss components of net periodic benefit costs outside of operating income will be offset by a corresponding increase in Other income, net, in the Consolidated Statements of Earnings. Refer to Note 15 to the Consolidated Financial Statements for the components impacting net period benefit cost for the year ended December 31, 2017. |
|--|--|---|

Date of adoption:
January 1, 2018

2. DISCONTINUED OPERATIONS AND ASSETS HELD FOR SALE

As part of a strategic portfolio review conducted in 2014, the Corporation identified certain businesses it considered non-core. The Corporation considers businesses non-core when their products or services do not complement existing businesses and where the long-term growth and profitability prospects are below the Corporation's expectations. As part of this initiative, the Corporation divested all five businesses during 2015 that were classified as held for sale as of December 31, 2014. The results of operations of these businesses are reported as discontinued operations within our Consolidated Statements of Earnings.

The aggregate financial results of all discontinued operations for the years ended December 31 were as follows:

| <i>(In thousands)</i> | 2017 | 2016 | 2015 |
|--|------|------------------------|-------------|
| Net sales | \$ — | \$ — | \$ 57,992 |
| Loss from discontinued operations before income taxes ⁽¹⁾ | — | — | (40,984) |
| Income tax benefit / (expense) | — | (2,053) ⁽³⁾ | 7,926 |
| Loss on sale of businesses ⁽²⁾ | — | — | (13,729) |
| Loss from discontinued operations | \$ — | \$ (2,053) | \$ (46,787) |

⁽¹⁾ Loss from discontinued operations before income taxes includes approximately \$40.8 million of held for sale impairment expense in the year ended December 31, 2015.

⁽²⁾ In the year ended December 31, 2015, the Corporation recognized aggregate after tax losses of \$13.7 million on the sale of the Aviation Ground, Downstream Oil & Gas, Engineered Packaging and two surface technology businesses.

⁽³⁾ Amount represents finalization of the income tax provision related to discontinued operations for the year ended December 31, 2015.

2015 Divestitures

Surface Technologies - Domestic

In October 2015 and July 2015, the Corporation sold the assets and liabilities of two surface technology treatment facilities for less than \$1 million. The businesses were previously classified within assets held for sale and reported within the Commercial/Industrial segment.

Engineered Packaging

In July 2015, the Corporation sold the assets and liabilities of its Engineered Packaging business for approximately \$14 million and recognized a pre-tax gain of \$2.3 million. The businesses were previously classified as assets held for sale and reported within the Defense segment.

Downstream

In May 2015, the Corporation completed the divestiture of its Downstream oil and gas business for \$19 million, net of transaction costs. During the fourth quarter of 2015, the Company paid a \$4.8 million working capital adjustment. The business was previously classified within assets held for sale. During 2015, the Corporation recognized a pre-tax loss on divestiture, including impairment charges, of \$59.5 million.

Aviation Ground

In January 2015, the Corporation sold the assets of its Aviation Ground support business for £3 million (\$4 million). The business was previously classified within assets held for sale and reported within the Defense segment.

3. ACQUISITIONS

The Corporation continually evaluates potential acquisitions that either strategically fit within the Corporation's existing portfolio or expand the Corporation's portfolio into new product lines or adjacent markets. The Corporation has completed a number of acquisitions that have been accounted for as business combinations and have resulted in the recognition of goodwill in the Corporation's financial statements. This goodwill arises because the purchase prices for these businesses reflect the future earnings and cash flow potential in excess of the earnings and cash flows attributable to the current product and customer set at the time of acquisition. Thus, goodwill inherently includes the know-how of the assembled workforce, the ability of the workforce to further improve the technology and product offerings, and the expected cash flows resulting from these efforts. Goodwill may also include expected synergies resulting from the complementary strategic fit these businesses bring to existing operations.

The Corporation allocates the purchase price at the date of acquisition based upon its understanding of the fair value of the acquired assets and assumed liabilities. In the months after closing, as the Corporation obtains additional information about these assets and liabilities, including through tangible and intangible asset appraisals, and as the Corporation learns more about the newly acquired business, it is able to refine the estimates of fair value and more accurately allocate the purchase price. Only items identified as of the acquisition date are considered for subsequent adjustment. The Corporation will make appropriate adjustments to the purchase price allocation prior to completion of the measurement period, as required.

During the twelve months ended December 31, 2017, the Corporation acquired two businesses for an aggregate purchase price of \$233 million, net of cash acquired, which is described in more detail below. During the twelve months ended December 31, 2016, no acquisitions were made.

The Consolidated Statement of Earnings for the twelve months ended December 31, 2017 includes \$71 million of total net sales and \$5 million of net earnings from the Corporation's 2017 acquisitions.

The following table summarizes the estimated fair values of the assets acquired and liabilities assumed at the date of acquisition for all acquisitions consummated during 2017:

| <i>(In thousands)</i> | 2017 |
|--------------------------------------|-------------|
| Accounts receivable | \$ 4,994 |
| Inventory | 22,702 |
| Property, plant, and equipment | 4,598 |
| Intangible assets | 88,900 |
| Other current and non-current assets | 2,816 |
| Current and non-current liabilities | (6,730) |
| Due to seller | (804) |
| Net tangible and intangible assets | 116,476 |
| Purchase price | 232,630 |
| Goodwill | \$ 116,154 |
| Goodwill deductible for tax purposes | \$ 115,532 |

2017 Acquisitions

Teletronics Technology Corporation (TTC)

On January 3, 2017, the Corporation acquired 100% of the issued and outstanding capital stock of TTC for \$226.0 million, net of cash acquired. The Share Purchase Agreement contains a purchase price adjustment mechanism and representations and warranties customary for a transaction of this type, including a portion of the purchase price deposited in escrow as security for potential indemnification claims against the seller. TTC is a designer and manufacturer of high-technology data acquisition and comprehensive flight test instrumentation systems for critical aerospace and defense applications. For the year ended December 31, 2016, TTC generated sales of \$64 million. The acquired business operates within the Defense segment.

Para Tech Coating, Inc. (Para Tech)

On February 8, 2017, the Corporation acquired certain assets and assumed certain liabilities of Para Tech for \$6.6 million in cash. The Asset Purchase Agreement contains a purchase price adjustment mechanism and representations and warranties customary for a transaction of this type, including a portion of the purchase price held back as security for potential indemnification claims against the seller. Para Tech is a provider of parylene conformal coating services for aerospace & defense electronic components as well as critical medical devices. The acquired business operates within the Commercial/Industrial segment.

4. RECEIVABLES

Receivables include current notes, amounts billed to customers, claims, other receivables, and unbilled revenue on long-term contracts, which consists of amounts recognized as sales but not billed. Substantially all amounts of unbilled receivables are expected to be billed and collected in the subsequent year. An immaterial amount of unbilled receivables are subject to retainage provisions. The amount of claims and unapproved change orders within our receivables balances are immaterial.

Credit risk is diversified due to the large number of entities comprising the Corporation's customer base and their geographic dispersion. The Corporation is either a prime contractor or subcontractor to various agencies of the U.S. Government. Revenues derived directly and indirectly from government sources (primarily the U.S. Government) were 39% and 38% of total net sales in 2017 and 2016, respectively. Total receivables due primarily from the U.S. Government were \$208.4 million and \$183.6 million as of December 31, 2017 and 2016, respectively. Government (primarily the U.S. Government) unbilled receivables, net of progress payments, were \$89.3 million and \$83.2 million as of December 31, 2017 and 2016, respectively.

The composition of receivables as of December 31 is as follows:

| <i>(In thousands)</i> | 2017 | 2016 |
|---|-----------|-----------|
| Billed receivables: | | |
| Trade and other receivables | \$363,234 | \$340,091 |
| Less: Allowance for doubtful accounts | (7,486) | (4,832) |
| Net billed receivables | 355,748 | 335,259 |
| Unbilled receivables: | | |
| Recoverable costs and estimated earnings not billed | 160,727 | 149,847 |
| Less: Progress payments applied | (21,552) | (22,044) |
| Net unbilled receivables | 139,175 | 127,803 |
| Receivables, net | \$494,923 | \$463,062 |

5. INVENTORIES

Inventoried costs contain amounts relating to long-term contracts and programs with long production cycles, a portion of which will not be realized within one year. Long term contract inventory includes an immaterial amount of claims or other similar items subject to uncertainty concerning their determination or realization. Inventories are valued at the lower of cost or market.

The composition of inventories as of December 31 is as follows:

| <i>(In thousands)</i> | 2017 | 2016 |
|--|-----------|-----------|
| Raw material | \$191,855 | \$189,228 |
| Work-in-process | 73,937 | 73,843 |
| Finished goods | 114,307 | 112,478 |
| Inventoried costs related to U.S. Government and other long-term contracts | 65,150 | 57,516 |
| Gross inventories | 445,249 | 433,065 |
| Less: Inventory reserves | (54,638) | (54,988) |
| Progress payments applied, principally related to long-term contracts | (11,745) | (11,103) |
| Inventories, net | \$378,866 | \$366,974 |

As of December 31, 2017 and 2016, inventory also includes capitalized contract development costs of \$35.0 million and \$28.8 million, respectively, related to certain aerospace and defense programs. These capitalized costs will be liquidated as production units are delivered to the customer. As of December 31, 2017 and 2016, \$5.4 million and \$3.9 million, respectively, are scheduled to be liquidated under existing firm orders.

6. PROPERTY, PLANT, AND EQUIPMENT

The composition of property, plant, and equipment as of December 31 is as follows:

| <i>(In thousands)</i> | 2017 | 2016 |
|---|-------------|-------------|
| Land | \$ 19,947 | \$ 19,511 |
| Buildings and improvements | 234,539 | 215,221 |
| Machinery, equipment, and other | 783,430 | 752,356 |
| Property, plant, and equipment, at cost | 1,037,916 | 987,088 |
| Less: Accumulated depreciation | (647,681) | (598,185) |
| Property, plant, and equipment, net | \$ 390,235 | \$ 388,903 |

Depreciation expense from continuing operations for the years ended December 31, 2017, 2016, and 2015 was \$61.6 million, \$62.6 million, and \$64.7 million, respectively.

7. GOODWILL

The changes in the carrying amount of goodwill for 2017 and 2016 are as follows:

| <i>(In thousands)</i> | Commercial /Industrial | Defense | Power | Consolidated |
|---|-----------------------------------|----------------|--------------|---------------------|
| December 31, 2015 | \$447,828 | \$337,603 | \$187,175 | \$ 972,606 |
| Divestitures | — | (452) | — | (452) |
| Foreign currency translation adjustment | (11,687) | (9,496) | 86 | (21,097) |
| December 31, 2016 | \$436,141 | \$327,655 | \$187,261 | \$ 951,057 |
| Acquisitions | 2,677 | 113,477 | | 116,154 |
| Divestitures | (1,168) | (647) | | (1,815) |
| Foreign currency translation adjustment | 10,881 | 19,847 | 205 | 30,933 |
| December 31, 2017 | \$448,531 | \$460,332 | \$187,466 | \$1,096,329 |

The purchase price allocations relating to the businesses acquired are initially based on estimates. The Corporation adjusts these estimates based upon final analysis, including input from third party appraisals when deemed appropriate. The determination of fair value is finalized no later than twelve months from acquisition. Goodwill adjustments represent subsequent adjustments to the purchase price allocation for acquisitions.

The Corporation completed its annual goodwill impairment testing as of October 31, 2017, 2016, and 2015 and concluded that there was no impairment of goodwill. The estimated fair value of each respective reporting unit substantially exceeded its recorded book value.

8. OTHER INTANGIBLE ASSETS, NET

Intangible assets are generally the result of acquisitions and consist primarily of purchased technology, customer related intangibles, and trademarks. Intangible assets are amortized over useful lives that generally range between 1 and 20 years.

The following tables present the cumulative composition of the Corporation's intangible assets as of December 31, 2017 and December 31, 2016, respectively.

| <i>(In thousands)</i> | 2017 | | | 2016 | | |
|------------------------------|------------------|--------------------------|------------------|------------------|--------------------------|------------------|
| | Gross | Accumulated Amortization | Net | Gross | Accumulated Amortization | Net |
| Technology | \$243,440 | \$(114,036) | \$129,404 | \$166,859 | \$(98,266) | \$68,593 |
| Customer related intangibles | 367,230 | (180,580) | 186,650 | 349,742 | (157,154) | 192,588 |
| Other intangible assets | 40,640 | (27,026) | 13,614 | 36,709 | (26,429) | 10,280 |
| Total | <u>\$651,310</u> | <u>\$(321,642)</u> | <u>\$329,668</u> | <u>\$553,310</u> | <u>\$(281,849)</u> | <u>\$271,461</u> |

During the year ended December 31, 2017, the Corporation acquired intangible assets of \$88.9 million which included Technology of \$73.0 million, Customer-related intangibles of \$12.9 million, and Other intangible assets of \$3.0 million. The weighted average amortization periods for these aforementioned intangible assets are 15.0 years, 16.3 years, and 7.0 years, respectively.

Amortization expense from continuing operations for the years ended December 31, 2017, 2016, and 2015 was \$38.4 million, \$33.4 million, and \$34.8 million, respectively. The estimated future amortization expense of intangible assets over the next five years is as follows:

| <i>(In thousands)</i> | |
|-----------------------|----------|
| 2018 | \$38,159 |
| 2019 | 36,405 |
| 2020 | 34,440 |
| 2021 | 32,644 |
| 2022 | 30,085 |

9. FAIR VALUE OF FINANCIAL INSTRUMENTS

Forward Foreign Exchange and Currency Option Contracts

The Corporation has foreign currency exposure primarily in the United Kingdom, Canada, and Europe. The Corporation uses financial instruments, such as forward and option contracts, to hedge a portion of existing and anticipated foreign currency denominated transactions. The purpose of the Corporation's foreign currency risk management program is to reduce volatility in earnings caused by exchange rate fluctuations. Guidance on accounting for derivative instruments and hedging activities requires companies to recognize all of the derivative financial instruments as either assets or liabilities at fair value in the Consolidated Balance Sheets.

Interest Rate Risks and Related Strategies

The Corporation's primary interest rate exposure results from changes in U.S. dollar interest rates. The Corporation's policy is to manage interest cost using a mix of fixed and variable rate debt. The Corporation periodically uses interest rate swaps to manage such exposures. Under these interest rate swaps, the Corporation exchanges, at specified intervals, the difference between fixed and floating interest amounts calculated by reference to an agreed-upon notional principal amount. The Corporation's foreign exchange contracts and interest rate swaps are considered Level 2 instruments which are based on market based inputs or unobservable inputs and corroborated by market data such as quoted prices, interest rates, or yield curves.

For interest rate swaps designated as fair value hedges (i.e., hedges against the exposure to changes in the fair value of an asset or a liability or an identified portion thereof that is attributable to a particular risk), changes in the fair value of the interest rate swaps offset changes in the fair value of the fixed rate debt due to changes in market interest rates.

In March 2013, the Corporation entered into fixed-to-floating interest rate swap agreements to convert the interest payments of (i) the \$100 million, 3.85% notes, due February 26, 2025, from a fixed rate to a floating interest rate based on 1-Month LIBOR plus a 1.77% spread, and (ii) the \$75 million, 4.05% notes, due February 26, 2028, from a fixed rate to a floating interest rate based on 1-Month LIBOR plus a 1.73% spread.

In January 2012, the Corporation entered into fixed-to-floating interest rate swap agreements to convert the interest payments of (i) the \$200 million, 4.24% notes, due December 1, 2026, from a fixed rate to a floating interest rate based on 1-Month LIBOR plus a 2.02% spread, and (ii) \$25 million of the \$100 million, 3.84% notes, due December 1, 2021, from a fixed rate to a floating interest rate based on 1-Month LIBOR plus a 1.90% spread.

On February 5, 2016, the Corporation terminated its March 2013 and January 2012 interest rate swap agreements. As a result of the termination, the Corporation received a cash payment of \$20.4 million, representing the fair value of the interest rate swaps on the date of termination. In connection with the termination, the Corporation and the counterparties released each other from all obligations under the interest rate swaps agreement, including, without limitation, the obligation to make periodic payments under such agreements. The gain on termination is reflected as a bond premium to our notes' carrying value and will be amortized into interest expense over the remaining terms of the Senior Notes.

Effects on Consolidated Balance Sheets

As of December 31, 2017 and December 31, 2016, the fair values of the asset and liability derivative instruments are immaterial.

Effects on Consolidated Statements of Earnings

Fair value hedge

The location and amount of losses on the hedged fixed rate debt attributable to changes in the market interest rates and the offsetting gains on the related interest rate swaps for the years ended December 31, were as follows:

| <i>(In thousands)</i> | Gain/(Loss) on Swap | | |
|------------------------|---------------------|------|-----------|
| | 2017 | 2016 | 2015 |
| Other income, net | | | |
| Interest rate swaps | \$— | \$— | \$ 8,204 |
| Hedged fixed rate debt | \$— | \$— | \$(8,204) |
| Total | \$— | \$— | \$ — |

Undesignated hedges

The location and amount of (gains) and losses recognized in income on forward exchange derivative contracts not designated for hedge accounting for the years ended December 31, were as follows:

| <i>(In thousands)</i> | 2017 | 2016 | 2015 |
|-------------------------------------|---------|----------|----------|
| Forward exchange contracts: | | | |
| General and administrative expenses | \$(346) | \$11,510 | \$11,042 |

Debt

The estimated fair value amounts were determined by the Corporation using available market information, which is primarily based on quoted market prices for the same or similar issues as of December 31, 2017. The fair value of our debt instruments are characterized as a Level 2 measurement which are based on

market based inputs or unobservable inputs and corroborated by market data such as quoted prices, interest rates, or yield curves. The estimated fair values of the Corporation's fixed rate debt instruments as of December 31, 2017, net of debt issuance costs, totaled \$822 million compared to a carrying value, net of debt issuance costs, of \$799 million. The estimated fair values of the Corporation's fixed rate debt instruments as of December 31, 2016, net of debt issuance costs, totaled \$961 million compared to a carrying value, net of debt issuance costs, of \$949 million.

The fair values described above may not be indicative of net realizable value or reflective of future fair values. Furthermore, the use of different methodologies to determine the fair value of certain financial instruments could result in a different estimate of fair value at the reporting date.

Nonrecurring measurements

As discussed in Note 2 to the Consolidated Financial Statements, the Corporation classified certain businesses as held for sale during 2014. In accordance with the provisions of the Impairment or Disposal of Long-Lived Assets guidance of FASB Codification Subtopic 360-10, the carrying amounts of the disposal groups were written down to their estimated fair value, less costs to sell, resulting in an impairment charge of \$40.8 million, which was included in the loss from discontinued operations before income taxes for the year ended December 31, 2015.

10. ACCRUED EXPENSES AND OTHER CURRENT LIABILITIES

Accrued expenses consist of the following as of December 31:

| <i>(In thousands)</i> | 2017 | 2016 |
|-------------------------------|------------------|-------------------|
| Accrued compensation | \$108,268 | \$ 85,970 |
| Accrued commissions | 6,296 | 5,189 |
| Accrued interest | 9,894 | 9,817 |
| Accrued insurance | 7,015 | 7,521 |
| Other | 18,933 | 21,742 |
| Total accrued expenses | \$150,406 | \$ 130,239 |

Other current liabilities consist of the following as of December 31:

| <i>(In thousands)</i> | 2017 | 2016 |
|---|-----------------|-----------------|
| Warranty reserves | \$14,212 | \$ 11,768 |
| Additional amounts due to sellers on acquisitions | 1,941 | 1,985 |
| Reserves on loss contracts | 1,418 | 1,662 |
| Pension and other postretirement liabilities | 5,060 | 5,331 |
| Other | 13,179 | 7,281 |
| Total other current liabilities | \$35,810 | \$28,027 |

11. INCOME TAXES

2017 Tax Cuts and Jobs Act

On December 22, 2017, the 2017 Tax Cuts and Jobs Act (the Tax Act) was enacted into law. The new legislation contains several key tax provisions, including a one-time mandatory transition tax on accumulated foreign earnings and a reduction of the U.S. corporate income tax rate to 21% effective January 1, 2018. The Corporation will generally be eligible for a 100% dividends received exemption on its foreign earnings starting in fiscal year 2018. However, it may also be subject to the Base Erosion Anti-Abuse Tax and Global Intangible Low Taxed Income (GILTI), both of which do not impact the Corporation until fiscal year 2018. The Corporation has not yet adopted an accounting policy related to the provision of deferred taxes for inside asset basis differences that could produce additional income subject to GILTI in the future. The Corporation anticipates that future issuance of U.S. Treasury department regulations and notices will clarify significant issues dealing with the application and computation of taxes due under the GILTI provisions.

In accordance with Staff Accounting Bulletin No. 118, *Income Tax Accounting Implications of the Tax Cuts and Jobs Act*, the Corporation recognized the income tax effects of the Tax Act in its consolidated financial statements for the year ended December 31, 2017, resulting in a net increase in its provision for income taxes of approximately \$10 million. The Corporation expects to finalize any provisional amounts associated with the Tax Act over the next 12 months based on an ongoing assessment of its tax positions and other relevant data.

The Corporation has summarized the most significant impacts from the Tax Act below:

Reduction of the U.S. Corporate Income Tax Rate

The Corporation measures deferred tax assets and liabilities using enacted tax rates that are applicable in the years in which the temporary differences are expected to be recovered or paid. Accordingly, the Corporation's deferred tax assets and liabilities were remeasured to reflect the reduction of the U.S. corporate income tax rate from 35 percent to 21 percent, resulting in a provisional \$13.4 million decrease in income tax expense for the year ended December 31, 2017 and a corresponding \$13.4 million decrease in net deferred tax liabilities as of December 31, 2017. The Corporation is still analyzing certain aspects of the Tax Act and refining its calculations, which could potentially affect the measurement of these balances or potentially give rise to new deferred tax amounts.

Transition Tax on Foreign Earnings

The Corporation recorded provisional income tax expense of \$18.2 million for the year ended December 31, 2017 related to the one-time transition tax on certain foreign earnings. Prior to assessing the impact of the Tax Act, the Corporation had a deferred tax liability of \$5.5 million for certain foreign subsidiaries whose earnings were not considered permanently reinvested. As of December 31, 2017, the Corporation's provisional income tax liability related to the transition tax was \$23.7 million. The transition tax will be paid over eight years, as permitted by the Tax Act, with the current balance of \$1.9 million recorded in current income tax payable as of December 31, 2017. The determination of the transition tax requires further analysis regarding the amount and composition of the Corporation's historical foreign earnings and tax pools. Given that all of its foreign undistributed earnings are no longer considered permanently reinvested, the Corporation also recorded provisional income tax expense of \$3.8 million for the year ended December 31, 2017 for withholding taxes that would arise upon ultimate distribution of all the Corporation's foreign undistributed earnings. The Corporation is considered permanently reinvested to the extent of any outside basis differences in its foreign subsidiaries in excess of the amount of undistributed earnings.

Earnings before income taxes for the years ended December 31 consist of:

| <i>(In thousands)</i> | 2017 | 2016 | 2015 |
|-----------------------|------------|------------|------------|
| Domestic | \$ 179,006 | \$ 154,571 | \$ 135,112 |
| Foreign | 120,613 | 113,390 | 140,082 |
| | \$ 299,619 | \$ 267,961 | \$ 275,194 |

The provision for income taxes for the years ended December 31 consists of:

| <i>(In thousands)</i> | 2017 | 2016 | 2015 |
|-----------------------------------|-----------------|-----------------|-----------------|
| Current: | | | |
| Federal | \$54,963 | \$45,523 | \$ (6,741) |
| State | 2,648 | 8,002 | 6,175 |
| Foreign | 23,162 | 20,861 | 27,134 |
| Total current | 80,773 | 74,386 | 26,568 |
| Deferred: | | | |
| Federal | 2,595 | 4,267 | 49,060 |
| State | 4,282 | 73 | 7,390 |
| Foreign | (2,922) | (147) | (72) |
| Total deferred | 3,955 | 4,193 | 56,378 |
| Provision for income taxes | \$84,728 | \$78,579 | \$82,946 |

The effective tax rate varies from the U.S. federal statutory tax rate for the years ended December 31, principally:

| | 2017 | 2016 | 2015 |
|---|--------------|--------------|--------------|
| U.S. federal statutory tax rate | 35.0% | 35.0% | 35.0% |
| Add (deduct): | | | |
| State and local taxes, net of federal benefit | 1.8 | 1.1 | 4.3 |
| R&D tax credits | (1.3) | (0.9) | (1.3) |
| Foreign earnings ⁽¹⁾ | (6.0) | (5.8) | (6.2) |
| Stock compensation - excess tax benefits | (2.6) | — | — |
| Impacts related to the Tax Act | 3.4 | — | — |
| All other, net | (2.0) | (0.1) | (1.7) |
| Effective tax rate | 28.3% | 29.3% | 30.1% |

⁽¹⁾ Foreign earnings primarily include the net impact of differences between local statutory rates and the U.S. Federal statutory rate, the cost of repatriating foreign earnings, and the impact of changes to foreign valuation allowances.

The components of the Corporation's deferred tax assets and liabilities as of December 31 are as follows:

| <i>(In thousands)</i> | 2017 | 2016 |
|--|------------------|------------------|
| Deferred tax assets: | | |
| Pension plans | \$ 18,903 | \$ 45,568 |
| Environmental reserves | 7,109 | 9,871 |
| Inventories | 15,116 | 21,758 |
| Postretirement/postemployment benefits | 8,241 | 13,542 |
| Incentive compensation | 7,721 | 9,425 |
| Net operating loss | 10,908 | 10,345 |
| Capital loss carryover | 7,047 | 11,352 |
| Other | 28,775 | 39,977 |
| Total deferred tax assets | 103,820 | 161,838 |
| Deferred tax liabilities: | | |
| Depreciation | 19,586 | 25,963 |
| Goodwill amortization | 67,779 | 97,667 |
| Other intangible amortization | 38,252 | 51,712 |
| Other | 12,636 | 16,225 |
| Total deferred tax liabilities | 138,253 | 191,567 |
| Valuation allowance | 12,322 | 17,776 |
| Net deferred tax liabilities | \$ 46,755 | \$ 47,505 |

Deferred tax assets and liabilities are reflected on the Corporation's consolidated balance sheet as of December 31 as follows:

| <i>(In thousands)</i> | 2017 | 2016 |
|---|-----------------|-----------------|
| Net noncurrent deferred tax assets | 2,605 | 2,217 |
| Net noncurrent deferred tax liabilities | 49,360 | 49,722 |
| Net deferred tax liabilities | \$46,755 | \$47,505 |

The Corporation has income tax net operating loss carryforwards related to international operations of \$24.0 million of which \$17.9 million have an indefinite life and \$6.1 million expire through 2023. The Corporation has federal and state income tax net loss carryforwards of \$104.1 million, of which \$73.0 million are net operating losses which expire through 2037 and \$31.1 million are capital loss carryforwards which expire through 2020. The Corporation has recorded a deferred tax asset of \$18 million reflecting the benefit of the loss carryforwards.

Management assesses the available positive and negative evidence to estimate if sufficient future taxable income will be generated to utilize the existing deferred tax assets. A significant piece of objective negative evidence evaluated was the cumulative loss incurred over the three-year period ended December 31, 2017 in certain of the Corporation's foreign locations. Such objective evidence limits the ability to consider other subjective evidence such as projections for future growth. The Corporation provisionally decreased its valuation allowance by \$5.5 million to \$12.3 million, as of December 31, 2017, in order to measure only the portion of the deferred tax asset that more likely than not will be realized. Of the \$5.5 million decrease in the valuation allowance, \$4.3 million was due to the reduction of the U.S. corporate income tax rate from 35 percent to 21 percent. The amount of the deferred tax asset considered realizable, however, could be adjusted if estimates of future taxable income during the carryforward period are reduced or if objective negative evidence in the form of cumulative losses is no longer present and additional weight may be given to subjective evidence such as projections for growth.

Income tax payments, net of refunds, of \$92.1 million, \$54.5 million, and \$4.9 million were made in 2017, 2016, and 2015, respectively.

The Corporation has recognized a liability in Other liabilities for interest of \$2.6 million and penalties of \$1.6 million as of December 31, 2017.

A reconciliation of the beginning and ending amount of unrecognized tax benefits is as follows:

| <i>(In thousands)</i> | 2017 | 2016 | 2015 |
|---|-------------|-------------|-------------|
| Balance as of January 1, | \$11,454 | \$12,414 | \$11,560 |
| Additions for tax positions of prior periods | 1,069 | 32 | 359 |
| Reductions for tax positions of prior periods | (194) | (1,679) | — |
| Additions for tax positions related to the current year | 1,273 | 789 | 2,026 |
| Settlements | (428) | (102) | (1,414) |
| Foreign currency translation | — | — | (117) |
| Balance as of December 31, | \$13,174 | \$11,454 | \$12,414 |

In many cases, the Corporation's uncertain tax positions are related to tax years that remain subject to examination by tax authorities.

The following describes the open tax years, by major tax jurisdiction, as of December 31, 2017:

| | |
|--------------------------------|----------------|
| United States (Federal) | 2014 - present |
| United States (Various states) | 2006 - present |
| United Kingdom | 2010 - present |
| Canada | 2011 - present |

The Corporation does not expect any significant changes to the estimated amount of liability associated with its uncertain tax positions through the next twelve months. Included in the total unrecognized tax benefits as of December 31, 2017, 2016, and 2015 is \$10.1 million, \$7.7 million, and \$8.3 million, respectively, which if recognized, would favorably affect the effective income tax rate.

12. DEBT

Debt consists of the following as of December 31:

| <i>(In thousands)</i> | 2017 | 2017 | 2016 | 2016 |
|---|----------------|----------------------|----------------|----------------------|
| | Carrying Value | Estimated Fair Value | Carrying Value | Estimated Fair Value |
| 5.51% Senior notes due 2017 | — | — | 150,000 | 154,509 |
| 3.84% Senior notes due 2021 | 100,000 | 102,472 | 100,000 | 102,463 |
| 3.70% Senior notes due 2023 | 225,000 | 228,783 | 225,000 | 226,946 |
| 3.85% Senior notes due 2025 | 100,000 | 102,164 | 100,000 | 100,338 |
| 4.24% Senior notes due 2026 | 200,000 | 208,873 | 200,000 | 203,592 |
| 4.05% Senior notes due 2028 | 75,000 | 76,997 | 75,000 | 74,630 |
| 4.11% Senior notes due 2028 | 100,000 | 103,226 | 100,000 | 99,876 |
| Other debt | 150 | 150 | 668 | 668 |
| Total debt | 800,150 | 822,665 | 950,668 | 963,022 |
| Debt issuance costs, net | (831) | (831) | (984) | (984) |
| Unamortized interest rate swap proceeds | 14,820 | 14,820 | 16,614 | 16,614 |
| Total debt, net | 814,139 | 836,654 | 966,298 | 978,652 |
| Less: current portion of long-term debt and short-term debt | 150 | 150 | 150,668 | 150,668 |
| Total long-term debt | \$813,989 | \$836,504 | \$815,630 | \$827,984 |

The Corporation did not have any borrowings against the Revolving Credit Agreement in 2017 and 2016, respectively.

The debt outstanding had fixed and variable interest rates averaging 3.9% in both 2017 and 2016, respectively.

Aggregate maturities of debt are as follows:

| <i>(In thousands)</i> | |
|-----------------------|-----------|
| 2018 | \$ 150 |
| 2019 | — |
| 2020 | — |
| 2021 | 100,000 |
| 2022 | — |
| Thereafter | 700,000 |
| Total | \$800,150 |

Interest payments of \$39 million, \$38 million, and \$33 million were made in 2017, 2016, and 2015, respectively.

Revolving Credit Agreement

In August 2012, the Corporation refinanced its existing credit facility by entering into a Third Amended and Restated Credit Agreement (Credit Agreement) with a syndicate of financial institutions, led by Bank of America N.A., Wells Fargo, N.A, and JP Morgan Chase Bank, N.A. The proceeds available under the Credit Agreement are to be used for working capital, internal growth initiatives, funding of future acquisitions, and general corporate purposes. Under the terms of the Credit Agreement, the Corporation has borrowing capacity of \$500 million. In addition, the Credit Agreement provides an accordion feature which allows the Corporation to borrow an additional \$100 million. As of December 31, 2017, the Corporation had \$21 million in letters of credit supported by the credit facility and no borrowings outstanding under the credit facility. The unused credit available under the credit facility as of December 31, 2017 was \$479 million, which the Corporation had the ability to borrow in full without violating its debt to capitalization covenant.

In December 2014, the Corporation amended its existing credit facility by entering into a Second Amendment to the Third Amended and Restated Credit Agreement (Credit Agreement) with a syndicate of financial institutions, led by Bank of America N.A., Wells Fargo, N.A, and JP Morgan Chase Bank, N.A. The amendment extends the maturity date of the agreement to November 2019. No other material modifications were made to the 2012 Credit Agreement.

The Credit Agreement contains covenants that the Corporation considers usual and customary for an agreement of this type for comparable commercial borrowers, including a maximum consolidated debt to capitalization ratio of 60%. The Credit Agreement has customary events of default, such as non-payment of principal when due; nonpayment of interest, fees, or other amounts; cross-payment default and cross-acceleration.

Borrowings under the credit agreement will accrue interest based on (i) Libor or (ii) a base rate of the highest of (a) the federal funds rate plus 0.5%, (b) BofA's announced prime rate, or (c) the Eurocurrency rate plus 1%, plus a margin. The interest rate and level of facility fees are dependent on certain financial ratios, as defined in the Credit Agreement. The Credit Agreement also provides customary fees, including administrative agent and commitment fees. In connection with the Credit Agreement, the Corporation paid customary transaction fees that have been deferred and are being amortized over the term of the Credit Agreement.

Senior Notes

On February 26, 2013, the Corporation issued \$500 million of Senior Notes (the "2013 Notes"). The 2013 Notes consist of \$225 million of 3.70% Senior Notes that mature on February 26, 2023, \$100 million of 3.85% Senior Notes that mature on February 26, 2025, and \$75 million of 4.05% Senior Notes that mature on February 26, 2028. \$100 million of additional 4.11% Senior Notes were deferred and subsequently issued on September 26, 2013 that mature on September 26, 2028. The 2013 Notes are senior unsecured obligations, equal in right of payment to the Corporation's existing senior indebtedness. The Corporation, at its option, can prepay at any time all or any part of the 2013 Notes, subject to a make-whole payment in accordance with the terms of the Note Purchase Agreement. In connection with the issuance of the 2013 Notes, the Corporation paid customary fees that have been deferred and are being amortized over the term of the 2013 Notes. Under the terms of the Note Purchase Agreement, the Corporation is required to maintain certain financial ratios, the most restrictive of which is a debt to capitalization limit of 60%. The debt to capitalization ratio (as defined per the Notes Purchase Agreement and Credit Agreement) is calculated using the same formula for all of the Corporation's debt agreements and is a measure of the Corporation's indebtedness to capitalization, where capitalization equals debt plus equity. As of December 31, 2017, the Corporation had the ability to borrow additional debt of \$1.4 billion without violating our debt to capitalization covenant. The 2013 Notes also contain a cross default provision with respect to the Corporation's other senior indebtedness.

On December 8, 2011, the Corporation issued \$300 million of Senior Notes (the "2011 Notes"). The 2011 Notes consist of \$100 million of 3.84% Senior Notes that mature on December 1, 2021 and \$200 million of 4.24% Senior Series Notes that mature on December 1, 2026. The 2011 Notes are senior unsecured obligations, equal in right of payment to our existing senior indebtedness. The Corporation, at its option, can prepay at any time all or any part of our 2011 Notes, subject to a make-whole payment in accordance with the terms of the Note Purchase Agreement. In connection with our 2011 Notes, the Corporation paid customary fees that have been deferred and are being amortized over the term of our 2011 Notes. Under the Note Purchase Agreement, the Corporation is required to maintain certain financial ratios, the most restrictive of which is a debt to capitalization limit of 60%. The 2011 Notes also contain a cross default provision with our other senior indebtedness.

On December 1, 2005, the Corporation issued \$150 million of 5.51% Senior Notes (the "2005 Notes"). The 2005 Notes, which matured on December 1, 2017 and were repaid in full, were senior unsecured obligations and equal in right of payment to the Corporation's existing senior indebtedness. In connection with the Notes, the Corporation paid customary fees that were deferred and amortized over the terms of the Notes.

13. EARNINGS PER SHARE

The Corporation is required to report both basic earnings per share (EPS), based on the weighted-average number of common shares outstanding, and diluted earnings per share, based on the basic EPS adjusted for all potentially dilutive shares issuable.

As of December 31, 2017, 2016, and 2015, there were no options outstanding that were considered anti-dilutive.

Earnings per share calculations for the years ended December 31, 2017, 2016, and 2015, are as follows:

| <i>(In thousands, except per share data)</i> | Earnings from continuing operations | Weighted-Average Shares Outstanding | Earnings per share from continuing operations |
|--|-------------------------------------|-------------------------------------|---|
| 2017 | | | |
| Basic earnings per share from continuing operations | \$214,891 | 44,182 | \$4.86 |
| Dilutive effect of stock options and deferred stock compensation | | 579 | |
| Diluted earnings per share from continuing operations | \$214,891 | 44,761 | \$4.80 |
| 2016 | | | |
| Basic earnings per share from continuing operations | \$189,382 | 44,389 | \$4.27 |
| Dilutive effect of stock options and deferred stock compensation | | 656 | |
| Diluted earnings per share from continuing operations | \$189,382 | 45,045 | \$4.20 |
| 2015 | | | |
| Basic earnings per share from continuing operations | \$192,248 | 46,624 | \$4.12 |
| Dilutive effect of stock options and deferred stock compensation | | 992 | |
| Diluted earnings per share from continuing operations | \$192,248 | 47,616 | \$4.04 |

14. SHARE-BASED COMPENSATION PLANS

In May 2014, the Corporation adopted the Curtiss Wright 2014 Omnibus Incentive Plan (the "2014 Omnibus Plan"). The plan replaced the Corporation's existing 2005 Long Term Incentive Plan and the 2005 Stock Plan for Non-Employee Directors (collectively the "2005 Stock Plans"). Beginning in May 2014, all awards were granted under the 2014 Omnibus Plan. The maximum aggregate number of shares of common stock that may be issued under the 2014 Omnibus Plan are 2,400,000 less one share of common stock for every one share of common stock granted under any prior plan after December 31, 2013 and prior to the effective date of the 2014 Omnibus Plan. In addition, any awards that were previously granted under any prior plan that terminate without issuance of shares, shall be eligible for issuance under the 2014 Omnibus Plan. Awards under the 2014 Omnibus Plan may be in the form of stock options, stock appreciation rights, restricted stock, restricted stock units (RSU), other stock-based awards, performance share units (PSU) or cash based performance units (PU).

During 2017, the Corporation granted awards in the form of RSUs, PSUs, and restricted stock. Previous grants under the 2005 Stock Plans included non-qualified stock options. Under our employee benefit program, the Corporation also provides an Employee Stock Purchase Plan (ESPP) available to most active employees. Certain awards provide for accelerated vesting if there is a change in control.

The compensation cost for employee and non-employee director share-based compensation programs during 2017, 2016, and 2015 is as follows:

| <i>(In thousands)</i> | 2017 | 2016 | 2015 |
|---|-----------------|----------------|----------------|
| Employee Stock Purchase Plan | 1,207 | 1,184 | 1,279 |
| Performance Share Units | 4,340 | 3,910 | 4,349 |
| Restricted Share Units | 4,931 | 3,426 | 3,015 |
| Other share-based payments | 1,094 | 958 | 830 |
| Total share-based compensation expense before income taxes | \$11,572 | \$9,478 | \$9,473 |

Other share-based grants include service-based restricted stock awards to non-employee directors, who are treated as employees as prescribed by the accounting guidance on share-based payments. The compensation cost recognized follows the cost of the employee, which is primarily reflected as General and administrative expenses in the Consolidated Statements of Earnings. No share-based compensation costs were capitalized during 2017, 2016, or 2015.

The following table summarizes the cash received from share-based awards on share-based compensation:

| <i>(In thousands)</i> | 2017 | 2016 | 2015 |
|---------------------------------------|----------|----------|----------|
| Cash received from share-based awards | \$14,179 | \$22,300 | \$28,706 |

A summary of employee stock option activity is as follows:

| | Shares (000's) | Weighted- Average Exercise Price | Weighted- Average Remaining Contractual Term in Years | Aggregate Intrinsic Value (000's) |
|-------------------------------------|-------------------|---|--|--|
| Outstanding as of December 31, 2016 | 443 | \$31.91 | | |
| Exercised | (179) | 34.24 | | |
| Outstanding as of December 31, 2017 | 264 | \$30.30 | 2.2 | \$24,093 |
| Exercisable as of December 31, 2017 | 264 | \$30.30 | 2.2 | \$24,093 |

The total intrinsic value of stock options exercised during 2017, 2016, and 2015 was \$30.2 million, \$43.2 million, and \$36.8 million, respectively.

Performance Share Units

The Corporation has granted performance share units to certain employees, whose three year cliff vesting is contingent upon the Corporation's total shareholder return over the three-year term of the awards compared to a self-constructed peer group. The non-vested shares are subject to forfeiture if established performance goals are not met or employment is terminated other than due to death, disability, or retirement. Share plans are denominated in share-based units based on the fair market value of the Corporation's common stock on the date of grant. The performance share unit's compensation cost is amortized to expense on a straight-line basis over the three-year requisite service period.

Restricted Share Units

Restricted share units cliff vest at the end of the awards' vesting period. The restricted share units are service-based and thus compensation cost is amortized to expense on a straight-line basis over the requisite service period, which is typically three years. The non-vested restricted units are subject to forfeiture if employment is terminated other than due to death, disability, or retirement.

A summary of the Corporation's 2017 activity related to performance share units and restricted share units are as follows:

| | Performance Share Units (PSUs) | | Restricted Share Units (RSUs) | |
|--|-----------------------------------|------------------------------------|----------------------------------|------------------------------------|
| | Shares/Units (000's) | Weighted- Average Fair Value | Shares/Units (000's) | Weighted- Average Fair Value |
| Nonvested as of December 31, 2016 | 204 | \$71.28 | 204 | \$74.38 |
| Granted | 68 | 62.91 | 1 | 98.34 |
| Vested | (137) | 62.91 | (34) | 70.36 |
| Forfeited | — | — | (2) | 85.47 |
| Nonvested as of December 31, 2017 | 135 | \$75.51 | 169 | \$75.19 |
| Expected to vest as of December 31, 2017 | 135 | \$75.51 | 169 | \$75.19 |

Nonvested PSUs had an intrinsic value of \$16.5 million and unrecognized compensation costs of \$4.7 million as of December 31, 2017. Nonvested RSUs had an intrinsic value of \$20.6 million and unrecognized compensation costs of \$5.9 million as of December 31, 2017. Unrecognized compensation costs related to PSUs and RSUs are both expected to be recognized over a period of 1.7 years.

Employee Stock Purchase Plan

The Corporation's ESPP enables eligible employees to purchase the Corporation's common stock at a price per share equal to 85% of the fair market value at the end of each offering period. Each offering period of the ESPP lasts six months, commencing on January 1st and July 1st of each year. Compensation cost is recognized on a straight-line basis over the six-month vesting period during which employees perform related services.

15. PENSION AND OTHER POSTRETIREMENT BENEFIT PLANS

The Corporation maintains ten separate and distinct pension and other post-retirement defined benefit plans, consisting of three domestic plans and seven separate foreign pension plans. Effective May 1, 2016, the Corporation completed the merger of three frozen UK defined benefit pension schemes by merging the Metal Improvement Company Salaried Staff Pension Scheme and the Mechetronics Limited Retirement Benefits Scheme into the Curtiss-Wright Penny & Giles Pension Plan. The Penny & Giles Plan was then renamed the Curtiss-Wright UK Pension Plan.

Effective December 31, 2014, the Corporation executed the following plan mergers: the two Williams Controls defined benefit pension plans were merged with the CW Pension Plan, resulting in one surviving domestic qualified plan, and the three domestic post-retirement health-benefits plans (CW, EMD, and Williams Controls) were merged into one. Post-merger, the Corporation maintains the following domestic plans: a qualified pension plan, a non-qualified pension plan, and a postretirement health-benefits plan. The foreign plans consist of one defined benefit pension plan each in the United Kingdom, Canada and Switzerland, two in Germany, and two in Mexico.

Domestic Plans

Qualified Pension Plan

The Corporation maintains a defined benefit pension plan (the "CW Pension Plan") covering certain employee populations under six benefit formulas: a non-contributory non-union and union formula for certain Curtiss-Wright (CW) employees, a contributory union and non-union benefit formula for employees at the EMD business unit, and two benefit formulas providing annuity benefits for participants in the former Williams Controls salaried and union plans.

CW non-union employees hired prior to February 1, 2010 receive a "traditional" benefit based on years of credited service, using the five highest consecutive years' compensation during the last ten years of service. These employees became participants under the CW Pension Plan after one year of service and were vested after three years of service. CW non-union employees hired on or after the effective date were eligible for a cash balance benefit through December 31, 2013, and were transitioned to the new

defined contribution plan, further described below. CW union employees who have negotiated a benefit under the CW Pension Plan are entitled to a benefit based on years of service multiplied by a monthly pension rate.

The formula for EMD employees covers both union and non-union employees and is designed to satisfy the requirements of relevant collective bargaining agreements. Employee contributions are withheld each pay period and are equal to 1.5% of salary. The benefits for the EMD employees are based on years of service and compensation. On December 31, 2012, the Corporation amended the CW Pension Plan to close the benefit to EMD employees hired after January 1, 2014.

Participants of the former Williams Controls Retirement Income Plan for salaried employees are either deferred vested participants or currently receiving benefits, as benefit accruals under the plan were frozen to future accruals effective January 1, 2003. Benefits in the salaried plan are based on average compensation and years of service.

Participants of the former Williams Controls UAW Local 492 Plan for union employees are entitled to a benefit based on years of service multiplied by a monthly pension rate, and may be eligible for supplemental benefits based upon attainment of certain age and service requirements.

In May 2013, the Company's Board of Directors approved an amendment to the CW Pension Plan. Effective January 1, 2014, all active non-union employees participating in the final and career average pay formulas in the defined benefit plan will cease accruals 15 years from the effective date of the amendment. In addition to the sunset provision, the "cash balance" benefit for non-union participants ceased as of January 1, 2014. Non-Union employees who are not currently receiving final or career average pay benefits became eligible to participate in a new defined contribution plan which provides both employer match and non-elective contribution components, up to a maximum employer contribution of 6%. The amendment does not affect CW employees that are subject to collective bargaining agreements.

As of December 31, 2017 and 2016, the Corporation had a noncurrent pension liability of \$45.1 million and \$40.4 million, respectively. This increase was primarily driven by a decrease in the discount rate as of December 31, 2017, partially offset by favorable asset experience during 2017.

Due to discretionary pension contributions of \$50 million and \$145 million to the Curtiss-Wright Pension Plan in February 2018 and January 2015, respectively, the Corporation does not expect to make any required contributions through 2022.

Nonqualified Pension Plan

The Corporation also maintains a non-qualified restoration plan (the "CW Restoration Plan") covering those employees of CW and EMD whose compensation or benefits exceed the IRS limitation for pension benefits. Benefits under the CW Restoration Plan are not funded, and, as such, the Corporation had an accrued pension liability of \$48.7 million and \$40.4 million as of December 31, 2017 and 2016, respectively. The Corporation's contributions to the CW Restoration Plan are expected to be \$3.0 million in 2018.

Other Post-Employment Benefits (OPEB) Plan

Under the plan merger effective December 31, 2014, the Corporation provides post-employment benefits consisting of retiree health and life insurance to three distinct groups of employees/retirees: the CW Grandfathered plan, and plans assumed in the acquisitions of EMD and Williams Controls.

In 2002, the Corporation restructured the postemployment medical benefits for then-active CW employees, effectively freezing the plan. The plan continues to be maintained for certain retired CW employees.

The Corporation also provides retiree health and life insurance benefits for substantially all of the Curtiss-Wright EMD employees. The plan provides basic health and welfare coverage for pre-65 participants based on years of service and are subject to certain caps. Effective January 1, 2011, the Corporation modified the benefit design for post-65 retirees by introducing Retiree Reimbursement Accounts (RRA's)

to participants in lieu of the traditional benefit delivery. Participant accounts are funded a set amount annually that can be used to purchase supplemental coverage on the open market, effectively capping the benefit.

The plan also provides retiree health and life insurance benefits for certain retirees of the Williams Controls salaried and union pension plans. Benefits are available to those employees who retired prior to December 31, 1993 in the salaried plan, and prior to October 1, 2003 in the union plan. Effective August 31, 2013, the Corporation modified the benefit design for post-65 retirees by introducing Retiree Reimbursement Accounts (RRA's) to align with the EMD delivery model.

The Corporation had an accrued postretirement benefit liability as of December 31, 2017 and 2016 of \$25.0 million and \$24.4 million, respectively. Pursuant to the EMD purchase agreement, the Corporation has a discounted receivable from Washington Group International to reimburse the Corporation for a portion of these post-retirement benefit costs. As of December 31, 2017 and 2016, the discounted receivable included in other assets was \$0.1 million and \$0.4 million, respectively. The Corporation expects to contribute \$1.7 million to the plan during 2018.

Foreign Plans

The foreign plans consist of one defined benefit pension plan each in the United Kingdom, Canada, and Switzerland, two in Germany, and two in Mexico. As of December 31, 2017 and 2016, the total projected benefit obligation related to all foreign plans was \$97.4 million and \$91.0 million, respectively. As of December 31, 2017 and 2016, the Corporation had a net pension asset of \$1.5 million and an accrued pension liability of \$3.3 million, respectively. The Corporation's contributions to the foreign plans are expected to be \$2.3 million in 2018.

Components of net periodic benefit expense

The net pension and net postretirement benefit costs (income) consisted of the following:

| <i>(In thousands)</i> | Pension Benefits | | | Postretirement Benefits | | |
|---|------------------|------------------|------------------|-------------------------|---------------|----------------|
| | 2017 | 2016 | 2015 | 2017 | 2016 | 2015 |
| Service cost | \$ 25,093 | \$ 25,100 | \$ 26,873 | \$ 435 | \$ 338 | \$ 286 |
| Interest cost | 25,895 | 30,495 | 30,050 | 762 | 996 | 842 |
| Expected return on plan assets | (53,552) | (54,101) | (54,629) | — | — | — |
| Amortization of prior service cost | (100) | (46) | 618 | (656) | (657) | (657) |
| Recognized net actuarial loss/(gain) | 12,925 | 12,029 | 16,890 | (223) | (296) | (551) |
| Cost of settlements/curtailments | 327 | — | 7,461 | — | — | — |
| Net periodic benefit cost (income) | \$ 10,588 | \$ 13,477 | \$ 27,263 | \$ 318 | \$ 381 | \$ (80) |

The cost of settlements/curtailments indicated above represents events that are accounted for under guidance on employers' accounting for settlements and curtailments of defined benefit pension plans. In 2017, there were settlement charges in both the U.K. and Switzerland. In 2015, the settlement charge was primarily a result of the retirement of the Corporation's former Chairman and his election to receive the nonqualified portion of his pension benefit as a single lump sum payout.

The following table outlines the Corporation's consolidated disclosure of the pension benefits and postretirement benefits information described previously. The Corporation had no foreign postretirement plans. All plans were valued using a December 31, 2017 measurement date.

| <i>(In thousands)</i> | Pension Benefits | | Postretirement Benefits | |
|---|--------------------|--------------------|-------------------------|--------------------|
| | 2017 | 2016 | 2017 | 2016 |
| Change in benefit obligation: | | | | |
| Beginning of year | \$798,605 | \$774,710 | \$24,436 | \$ 21,980 |
| Service cost | 25,093 | 25,100 | 435 | 338 |
| Interest cost | 25,895 | 30,495 | 762 | 996 |
| Plan participants' contributions | 1,655 | 1,897 | 253 | 266 |
| Amendments | — | — | — | — |
| Actuarial loss | 56,727 | 19,640 | 2,056 | 3,372 |
| Benefits paid | (45,384) | (41,115) | (2,907) | (2,516) |
| Actual expenses | (1,301) | (1,206) | — | — |
| Currency translation adjustments | 7,597 | (10,916) | — | — |
| End of year | \$868,887 | \$798,605 | \$ 25,035 | \$ 24,436 |
| Change in plan assets: | | | | |
| Beginning of year | \$714,608 | \$692,074 | \$ — | \$ — |
| Actual return on plan assets | 94,960 | 65,872 | — | — |
| Employer contribution | 4,561 | 8,210 | 2,654 | 2,250 |
| Plan participants' contributions | 1,655 | 1,897 | 253 | 266 |
| Benefits paid | (45,384) | (41,115) | (2,907) | (2,516) |
| Actual Expenses | (1,301) | (1,206) | — | — |
| Currency translation adjustments | 7,383 | (11,124) | — | — |
| End of year | \$776,482 | \$714,608 | \$ — | \$ — |
| Funded status | \$ (92,405) | \$ (83,997) | \$ (25,035) | \$ (24,436) |
| Amounts recognized on the balance sheet | | | | |
| Noncurrent assets | \$ 8,663 | \$ 4,049 | \$ — | \$ — |
| Current liabilities | (3,374) | (3,498) | (1,686) | (1,833) |
| Noncurrent liabilities | (97,694) | (84,548) | (23,349) | (22,603) |
| Total | \$ (92,405) | \$ (83,997) | \$ (25,035) | \$ (24,436) |
| Amounts recognized in accumulated other comprehensive income (AOCI) | | | | |
| Net actuarial loss (gain) | \$201,390 | \$198,630 | \$ (2,899) | \$ (5,178) |
| Prior service cost | (1,461) | (1,580) | (2,718) | (3,373) |
| Total | \$199,929 | \$197,050 | \$ (5,617) | \$ (8,551) |
| Amounts in AOCI expected to be recognized in net periodic cost in the coming year: | | | | |
| Loss (gain) recognition | \$ 15,615 | \$ 11,793 | \$ (29) | \$ (203) |
| Prior service cost recognition | \$ (250) | \$ (105) | \$ (657) | \$ (657) |
| Accumulated benefit obligation | \$834,745 | \$767,461 | N/A | N/A |
| Information for pension plans with an accumulated benefit obligation in excess of plan assets: | | | | |
| Projected benefit obligation | \$785,039 | \$733,426 | N/A | N/A |
| Accumulated benefit obligation | 752,371 | 702,282 | N/A | N/A |
| Fair value of plan assets | 684,756 | 645,380 | N/A | N/A |

Plan Assumptions

| | Pension Benefits | | Postretirement Benefits | |
|--|------------------|-------|-------------------------|-------|
| | 2017 | 2016 | 2017 | 2016 |
| Weighted-average assumptions in determination of benefit obligation: | | | | |
| Discount rate | 3.46% | 3.88% | 3.54% | 4.00% |
| Rate of compensation increase | 3.55% | 3.35% | N/A | N/A |
| Health care cost trends: | | | | |
| Rate assumed for subsequent year | N/A | N/A | 8.30% | 8.25% |
| Ultimate rate reached in 2026 | N/A | N/A | 4.50% | 4.50% |
| Weighted-average assumptions in determination of net periodic benefit cost: | | | | |
| Discount rate | 3.93% | 4.12% | 4.02% | 4.25% |
| Expected return on plan assets | 7.47% | 7.81% | N/A | N/A |
| Rate of compensation increase | 3.54% | 3.35% | N/A | N/A |
| Health care cost trends: | | | | |
| Rate assumed for subsequent year | N/A | N/A | 8.25% | 8.75% |
| Ultimate rate reached in 2026 | N/A | N/A | 4.50% | 4.50% |

Effective December 31, 2016, the Corporation adopted the spot rate, or full yield curve, approach for developing discount rates. The discount rate for each plan's past service liabilities and service cost is determined by discounting the plan's expected future benefit payments using a yield curve developed from high quality bonds that are rated Aa or better by Moody's as of the measurement date. The yield curve calculation matches the notional cash inflows of the hypothetical bond portfolio with the expected benefit payments to arrive at one effective rate for these components. Interest cost is determined by applying the spot rate from the full yield curve to each anticipated benefit payment, based on the anticipated optional form elections.

The overall expected return on assets assumption is based on a combination of historical performance of the pension fund and expectations of future performance. Expected future performance is determined by weighting the expected returns for each asset class by the plan's asset allocation. The expected returns are based on long-term capital market assumptions utilizing a ten-year time horizon through consultation with investment advisors. While consideration is given to recent performance and historical returns, the assumption represents a long-term prospective return.

The effect on the Other Post-Employment Benefits plan of a 1% change in the health care cost trend is as follows:

| <i>(In thousands)</i> | 1% Increase | 1% Decrease |
|--|-------------|-------------|
| Total service and interest cost components | \$ 28 | \$ (23) |
| Postretirement benefit obligation | \$502 | \$(414) |

Pension Plan Assets

The overall objective for plan assets is to earn a rate of return over time to meet anticipated benefit payments in accordance with plan provisions. The long-term investment objective of the domestic retirement plans is to achieve a total rate of return, net of fees, which exceeds the actuarial overall expected return on asset assumptions used for funding purposes and which provides an appropriate premium over inflation. The intermediate-term objective of the domestic retirement plans, defined as three to five years, is to outperform each of the capital markets in which assets are invested, net of fees. During periods of extreme market volatility, preservation of capital takes a higher precedence than outperforming the capital markets.

The Finance Committee of the Corporation's Board of Directors is responsible for formulating investment policies, developing investment manager guidelines and objectives, and approving and managing qualified advisors and investment managers. The guidelines established define permitted investments within each asset class and apply certain restrictions such as limits on concentrated holdings, and prohibits selling securities short, buying on margin, and the purchase of any securities issued by the Corporation.

The Corporation maintains the funds of the CW Pension Plan under a trust that is diversified across investment classes and among investment managers to achieve an optimal balance between risk and return. As a part of its diversification strategy, the Corporation has established target allocations for each of the following assets classes: domestic equity securities, international equity securities, and debt securities. Below are the Corporation's actual and established target allocations for the CW Pension Plan, representing 87% of consolidated assets:

| | As of December 31, | | Target | Expected |
|------------------------|--------------------|------|----------|----------|
| | 2017 | 2016 | Exposure | Range |
| Asset class | | | | |
| Domestic equities | 52% | 54% | 50% | 40%-60% |
| International equities | 15% | 13% | 15% | 10%-20% |
| Total equity | 67% | 67% | 65% | 55%-75% |
| Fixed income | 33% | 33% | 35% | 25%-45% |

As of December 31, 2017 and 2016, cash funds in the CW Pension Plan represented approximately 6% and 3% of portfolio assets, respectively.

Foreign plan assets represent 13% of consolidated plan assets, with the majority of the assets supporting the U.K. plan. Generally, the foreign plans follow a similar asset allocation strategy and are more heavily weighted in fixed income resulting in a weighted expected return on assets assumption of 3.90% for all foreign plans.

The Corporation may from time to time require the reallocation of assets in order to bring the retirement plans into conformity with these ranges. The Corporation may also authorize alterations or deviations from these ranges where appropriate for achieving the objectives of the retirement plans.

Fair Value Measurements

The following table presents consolidated plan assets (in thousands) as of December 31, 2017 using the fair value hierarchy, as described in Note 9 to the Consolidated Financial Statements.

| Asset Category | Total | Quoted Prices | | |
|--|-----------|--|---|---|
| | | in Active Markets for Identical Assets (Level 1) | Significant Observable Inputs (Level 2) | Significant Unobservable Inputs (Level 3) |
| Cash and cash equivalents | \$ 23,979 | \$ 4,893 | \$ 19,086 | \$ — |
| Equity securities- Mutual funds ⁽¹⁾ | 459,002 | 418,390 | 40,612 | — |
| Bond funds ⁽²⁾ | 219,249 | 155,120 | 64,129 | — |
| Insurance Contracts ⁽³⁾ | 10,760 | — | — | 10,760 |
| Other ⁽⁴⁾ | 1,618 | — | — | 1,618 |
| December 31, 2016 | \$714,608 | \$578,403 | \$123,827 | \$12,378 |
| Cash and cash equivalents | \$ 42,374 | \$ 12,551 | \$ 29,823 | \$ — |
| Equity securities- Mutual funds ⁽¹⁾ | 504,633 | 455,175 | 49,458 | — |
| Bond funds ⁽²⁾ | 216,372 | 150,265 | 66,107 | — |
| Insurance Contracts ⁽³⁾ | 10,912 | — | — | 10,912 |
| Other ⁽⁴⁾ | 2,191 | — | — | 2,191 |
| December 31, 2017 | \$776,482 | \$617,991 | \$145,388 | \$13,103 |

⁽¹⁾ This category consists of domestic and international equity securities. It is comprised of U.S. securities benchmarked against the S&P 500 index and Russell 2000 index, international mutual funds benchmarked against the MSCI EAFE index, global equity index mutual funds associated with our U.K. based pension plans and balanced funds associated with the U.K. and Canadian based pension plans.

(2) This category consists of domestic and international bonds. The domestic fixed income securities are benchmarked against the Barclays Capital Aggregate Bond index, actively-managed bond mutual funds comprised of domestic investment grade debt, fixed income derivatives, and below investment-grade issues, U.S. mortgage backed securities, asset backed securities, municipal bonds, and convertible debt. International bonds consist of bond mutual funds for institutional investors associated with the CW Pension Plan, Switzerland, and U.K. based pension plans.

(3) This category consists of a guaranteed investment contract (GIC) in Switzerland. Amounts contributed to the plan are guaranteed by a foundation for occupational benefits that in turn entered into a group insurance contract and the foundation pays a guaranteed rate of interest that is reset annually.

(4) This category consists primarily of real estate investment trusts in Switzerland.

Valuation

Equity securities and exchange-traded equity and bond mutual funds are valued using a market approach based on the quoted market prices of identical instruments. Pooled institutional funds are valued at their net asset values and are calculated by the sponsor of the fund.

Fixed income securities are primarily valued using a market approach utilizing various underlying pricing sources and methodologies. Real estate investment trusts are priced at net asset value based on valuations of the underlying real estate holdings using inputs such as discounted cash flows, independent appraisals, and market-based comparable data.

Cash balances in the United States are held in a pooled fund and classified as a Level 2 asset. Non-U.S. cash is valued using a market approach based on quoted market prices of identical instruments.

The following table presents a reconciliation of Level 3 assets held during the years ended December 31, 2017 and 2016:

| <i>(In thousands)</i> | Insurance Contracts | Other | Total |
|---|--------------------------------|----------------|-----------------|
| December 31, 2015 | \$ 9,720 | \$ 755 | \$10,475 |
| Actual return on plan assets: | | | |
| Relating to assets still held at the reporting date | 148 | 35 | 183 |
| Purchases, sales, and settlements | 1,095 | 871 | 1,966 |
| Foreign currency translation adjustment | (203) | (43) | (246) |
| December 31, 2016 | \$10,760 | \$1,618 | \$12,378 |
| Actual return on plan assets: | | | |
| Relating to assets still held at the reporting date | 167 | 58 | 226 |
| Purchases, sales, and settlements | (503) | 436 | (68) |
| Foreign currency translation adjustment | 488 | 79 | 567 |
| December 31, 2017 | <u>\$10,912</u> | <u>\$2,191</u> | <u>\$13,103</u> |

Benefit Payments

The following benefit payments, which reflect expected future service, as appropriate, are expected to be paid from the plans:

| <i>(In thousands)</i> | Pension Plans | Postretirement Plans | Total |
|-----------------------|---------------|----------------------|-----------|
| 2018 | \$ 45,604 | \$ 1,686 | \$ 47,290 |
| 2019 | 48,937 | 1,693 | 50,630 |
| 2020 | 49,859 | 1,694 | 51,553 |
| 2021 | 51,058 | 1,689 | 52,747 |
| 2022 | 50,361 | 1,678 | 52,039 |
| 2023 — 2027 | 266,582 | 8,030 | 274,612 |

Defined Contribution Retirement Plans

The Corporation offers all of its domestic employees the opportunity to participate in a defined contribution plan. Costs incurred by the Corporation in the administration and record keeping of the defined contribution plan are paid for by the Corporation and are not considered material.

Effective January 1, 2014, all non-union employees who were not currently receiving final or career average pay benefits became eligible to receive employer contributions in the Corporation's sponsored 401(k) plan. The employer contributions include both employer match and non-elective contribution components, up to a maximum employer contribution of 6% of eligible compensation. During the year ended December 31, 2017, the expense relating to the plan was \$12.9 million, consisting of \$5.8 million in matching contributions to the plan in 2017, and \$7.1 million in non-elective contributions paid in January 2018. Cumulative contributions of approximately \$69 million are expected to be made from 2018 through 2022.

In addition, the Corporation had foreign pension costs under various defined contribution plans of \$4.2 million, \$4.2 million, and \$4.8 million in 2017, 2016, and 2015, respectively.

16. LEASES

The Corporation conducts a portion of its operations from leased facilities, which include manufacturing and service facilities, administrative offices, and warehouses. In addition, the Corporation leases vehicles, machinery, and office equipment under operating leases. The leases expire at various dates and may include renewals and escalations. Rental expenses for all operating leases amounted to \$37.1 million, \$35.3 million, and \$37.0 million in 2017, 2016, and 2015, respectively.

As of December 31, 2017, the approximate future minimum rental commitments under operating leases that have initial or remaining non-cancelable lease terms in excess of one year are as follows:

| <i>(In thousands)</i> | Rental Commitments |
|-----------------------|--------------------|
| 2018 | \$ 28,284 |
| 2019 | 24,378 |
| 2020 | 21,733 |
| 2021 | 17,577 |
| 2022 | 14,253 |
| Thereafter | 73,870 |
| Total | <u>\$ 180,095</u> |

17. SEGMENT INFORMATION

The Corporation's segments are composed of similar product groupings that serve the same or similar end markets. Based on this approach, the Corporation has three reportable segments: Commercial/Industrial, Defense, and Power, as described below in further detail.

The Commercial/Industrial reportable segment is comprised of businesses that provide a diversified offering of highly engineered products and services supporting critical applications primarily across the commercial aerospace and general industrial markets. The products offered include electronic throttle control devices and transmission shifters, electro-mechanical actuation control components, valves, and surface technology services such as shot peening, laser peening, coatings, and advanced testing.

The Defense reportable segment is comprised of businesses that primarily provide products to the defense markets and to a lesser extent the commercial aerospace market. The products offered include commercial off-the-shelf (COTS) embedded computing board level modules, integrated subsystems, turret aiming and stabilization products, weapons handling systems, avionics and electronics, flight test equipment, and aircraft data management solutions.

The Power segment is comprised of businesses that primarily provide products to the power generation markets and to a lesser extent the naval defense market. The products offered include main coolant pumps, power-dense compact motors, generators, secondary propulsion systems, pumps, pump seals, control rod drive mechanisms, fastening systems, specialized containment doors, airlock hatches, spent fuel management products, and fluid sealing products.

The Corporation's measure of segment profit or loss is operating income. Interest expense and income taxes are not reported on an operating segment basis as they are not considered in the segments' performance evaluation by the Corporation's chief operating decision-maker, its Chief Executive Officer.

Net sales and operating income by reportable segment are as follows:

| | Year Ended December 31, | | |
|--|-------------------------|---------------------|---------------------|
| <i>(In thousands)</i> | 2017 | 2016 | 2015 |
| Net sales | | | |
| Commercial/Industrial | \$ 1,163,510 | \$ 1,120,326 | \$ 1,189,120 |
| Defense | 557,954 | 469,796 | 479,528 |
| Power | 554,048 | 524,967 | 545,013 |
| Less: Intersegment Revenues | (4,486) | (6,158) | (7,978) |
| Total Consolidated | <u>\$ 2,271,026</u> | <u>\$ 2,108,931</u> | <u>\$ 2,205,683</u> |
| Operating income (expense) | | | |
| Commercial/Industrial | \$ 168,328 | \$ 156,550 | \$ 171,525 |
| Defense | 109,355 | 98,291 | 98,895 |
| Power | 85,260 | 76,472 | 74,987 |
| Corporate and Eliminations ⁽¹⁾ | (23,200) | (23,215) | (34,790) |
| Total Consolidated | <u>\$ 339,743</u> | <u>\$ 308,098</u> | <u>\$ 310,617</u> |
| Depreciation and amortization expense | | | |
| Commercial/Industrial | \$ 53,180 | \$ 53,970 | \$ 55,799 |
| Defense | 20,702 | 14,488 | 15,965 |
| Power | 22,019 | 23,032 | 23,419 |
| Corporate | 4,094 | 4,518 | 4,292 |
| Total Consolidated | <u>\$ 99,995</u> | <u>\$ 96,008</u> | <u>\$ 99,475</u> |

| <i>(In thousands)</i> | 2017 | 2016 | 2015 |
|-----------------------------------|---------------------|---------------------|---------------------|
| Segment assets | | | |
| Commercial/Industrial | \$ 1,444,097 | \$ 1,391,040 | \$ 1,480,052 |
| Defense | 1,044,776 | 751,859 | 800,613 |
| Power | 482,753 | 516,321 | 629,612 |
| Corporate | 264,695 | 378,561 | 79,334 |
| Total Consolidated | <u>\$ 3,236,321</u> | <u>\$ 3,037,781</u> | <u>\$ 2,989,611</u> |
| Capital expenditures | | | |
| Commercial/Industrial | \$ 29,028 | \$ 30,145 | \$ 21,990 |
| Defense | 9,276 | 5,870 | 3,834 |
| Power | 10,039 | 6,653 | 6,163 |
| Corporate | 4,362 | 4,108 | 3,525 |
| Total Consolidated ⁽²⁾ | <u>\$ 52,705</u> | <u>\$ 46,776</u> | <u>\$ 35,512</u> |

⁽¹⁾ Corporate and Eliminations includes pension expense, environmental remediation and administrative expenses, legal, foreign currency transactional gains and losses, and other expenses.

⁽²⁾ Total capital expenditures included \$0.2 million of expenditures related to discontinued operations for the year ended 2015.

Reconciliations

| <i>(In thousands)</i> | Year Ended December 31, | | |
|--|-------------------------|-------------------|-------------------|
| | 2017 | 2016 | 2015 |
| Earnings before taxes: | | | |
| Total segment operating income | \$ 362,943 | \$ 331,313 | \$ 345,407 |
| Corporate and Eliminations | (23,200) | (23,215) | (34,790) |
| Interest expense | 41,471 | 41,248 | 36,038 |
| Other income, net | 1,347 | 1,111 | 615 |
| Total consolidated earnings before tax | <u>\$ 299,619</u> | <u>\$ 267,961</u> | <u>\$ 275,194</u> |

| <i>(In thousands)</i> | As of December 31, | | |
|--------------------------------------|---------------------|---------------------|---------------------|
| | 2017 | 2016 | 2015 |
| Assets: | | | |
| Total assets for reportable segments | \$ 2,971,626 | \$ 2,659,220 | \$ 2,910,277 |
| Non-segment cash | 204,664 | 357,021 | 42,164 |
| Other assets | 60,031 | 21,540 | 37,170 |
| Total consolidated assets | <u>\$ 3,236,321</u> | <u>\$ 3,037,781</u> | <u>\$ 2,989,611</u> |

Geographic Information

| <i>(In thousands)</i> | Year Ended December 31, | | |
|--------------------------|-------------------------|---------------------|---------------------|
| | 2017 | 2016 | 2015 |
| Revenues | | | |
| United States of America | \$ 1,562,180 | \$ 1,472,241 | \$ 1,502,363 |
| United Kingdom | 118,350 | 114,752 | 135,673 |
| Other foreign countries | 590,496 | 521,938 | 567,647 |
| Consolidated total | <u>\$ 2,271,026</u> | <u>\$ 2,108,931</u> | <u>\$ 2,205,683</u> |

| | As of December 31, | | |
|---------------------------|--------------------|------------------|------------------|
| <i>(In thousands)</i> | 2017 | 2016 | 2015 |
| Long-Lived Assets | | | |
| United States of America | \$264,829 | \$272,826 | \$293,612 |
| United Kingdom | 41,100 | 39,014 | 36,061 |
| Other foreign countries | 84,306 | 77,063 | 83,971 |
| Consolidated total | \$390,235 | \$388,903 | \$413,644 |

Net sales by product line

| | Year Ended December 31, | | |
|---------------------------|-------------------------|--------------------|--------------------|
| <i>(In thousands)</i> | 2017 | 2016 | 2015 |
| Net sales | | | |
| Flow Control | \$ 899,705 | \$ 883,735 | \$ 949,657 |
| Motion Control | 1,075,218 | 940,162 | 947,758 |
| Surface Technologies | 296,103 | 285,034 | 308,268 |
| Consolidated total | \$2,271,026 | \$2,108,931 | \$2,205,683 |

The Flow Control products include valves, pumps, motors, generators, and instrumentation that manage the flow of liquids and gases, generate power, and monitor or provide critical functions. Motion Control's products include turret aiming and stabilization products, embedded computing board level modules, electronic throttle control devices, transmission shifters, and electro-mechanical actuation control components. Surface Technologies include shot peening, laser peening, and coatings services that enhance the durability, extend the life, and prevent premature fatigue and failure on customer-supplied metal components.

18. CONTINGENCIES AND COMMITMENTS

Legal Proceedings

The Corporation has been named in a number of lawsuits that allege injury from exposure to asbestos. To date, the Corporation has not been found liable for or paid any material sum of money in settlement in any case. The Corporation believes its minimal use of asbestos in its past operations and the relatively non-friable condition of asbestos in its products make it unlikely that it will face material liability in any asbestos litigation, whether individually or in the aggregate. The Corporation maintains insurance coverage for these potential liabilities and believes adequate coverage exists to cover any unanticipated asbestos liability.

In December 2013, the Corporation, along with other unaffiliated parties, received a claim from Canadian Natural Resources Limited (CNRL) filed in the Court of Queen's Bench of Alberta, Judicial District of Calgary. The claim pertains to a January 2011 fire and explosion at a delayed coker unit at its Fort McMurray refinery that resulted in the injury of five CNRL employees, damage to property and equipment, and various forms of consequential loss such as loss of profit, lost opportunities, and business interruption. The fire and explosion occurred when a CNRL employee bypassed certain safety controls and opened an operating coker unit. The total quantum of alleged damages arising from the incident has not been finalized, but is estimated to meet or exceed \$1 billion. The Corporation maintains various forms of commercial, property and casualty, product liability, and other forms of insurance; however, such insurance may not be adequate to cover the costs associated with a judgment against us. In October 2017, all parties agreed in principle to participate in a formal mediation in late 2018 with the intention of settling this claim. In an effort to induce the parties to participate in the formal mediation, CNRL agreed to reduce its claim to approximately \$400 million, which reflects the monetary amount of property damage incurred as a result of the fire and explosion. The Corporation is currently unable to estimate an amount, or range of potential losses, if any, from this matter. The Corporation believes that it has adequate legal defenses and intends to defend this matter vigorously. The Corporation's financial condition, results of operations, and cash flows could be materially affected during a future fiscal quarter or fiscal year by unfavorable developments or outcome regarding this claim.

The Corporation is party to a number of other legal actions and claims, none of which individually or in the aggregate, in the opinion of management, are expected to have a material effect on the Corporation's results of operations or financial position.

WEC Bankruptcy

On March 29, 2017, WEC filed for Chapter 11 bankruptcy protection in the United States Bankruptcy Court for the Southern District of New York, Case No. 17-10751. The Bankruptcy Court overseeing the Bankruptcy Case has approved, on an interim basis, an \$800 million Debtor-in-Possession Financing Facility to help WEC finance its business operations during the reorganization process. On January 4, 2018, WEC announced that it had agreed to be acquired by Brookfield Business Partners L.P for approximately \$4.6 billion with the acquisition expected to close in the third quarter of 2018. The acquisition is not expected to have a material impact on the Corporation's financial condition or results of operations as WEC plans to continue operating in the ordinary course of business under existing senior management.

The Corporation had approximately \$4.9 million in pre-petition billings outstanding with WEC as of December 31, 2017. On January 29, 2018, the Corporation received notice that WEC filed its Plan of Reorganization. Under the Plan, the Corporation is expected to recover substantially all of its general unsecured claims, including pre-petition billings. The Plan of Reorganization is subject to approval, with voting tentatively scheduled for March 15, 2018. As it relates to post-petition work, the Corporation will continue to honor its executory contracts and expects to collect all amounts due. The Corporation will continue to monitor and evaluate the status of the WEC bankruptcy and Plan of Reorganization for potential impacts on its business.

Letters of Credit and Other Arrangements

The Corporation enters into standby letters of credit agreements and guarantees with financial institutions and customers primarily relating to guarantees of repayment, future performance on certain contracts to provide products and services, and to secure advance payments from certain international customers. As of December 31, 2017 and 2016, there were \$21.3 million and \$47.2 million of stand-by letters of credit outstanding, respectively, and \$14.6 million and \$12.8 million of bank guarantees outstanding, respectively.

The Corporation, through its Electro-Mechanical Division (EMD) business unit, has three Pennsylvania Department of Environmental Protection (PADEP) radioactive materials licenses that are utilized in the continued operation of the EMD business. In connection with these licenses, the Corporation has known conditional asset retirement obligations related to asset decommissioning activities to be performed in the future, when the Corporation terminates these licenses. For two of the three licenses, the Corporation has recorded an asset retirement obligation of approximately \$7.4 million. For its third license, the Corporation has not recorded an asset retirement obligation as it is not reasonably estimable due to insufficient information about the timing and method of settlement of the obligation. Accordingly, this obligation has not been recorded in the Consolidated Financial Statements. A liability for this obligation will be recorded in the period when sufficient information regarding timing and method of settlement becomes available to make a reasonable estimate of the liability's fair value. The Corporation is required to provide the Nuclear Regulatory Commission financial assurance demonstrating its ability to cover the cost of decommissioning its Cheswick, Pennsylvania facility upon closure, though the Corporation does not intend to close this facility. The Corporation has provided this financial assurance in the form of a \$56.0 million surety bond.

AP1000 Program

Within the Corporation's Power segment, the Electro-Mechanical Division is the RCP supplier for the WEC AP1000 nuclear power plants under construction in China and the United States. The terms of the AP1000 China and U.S. contracts include liquidated damage provisions for failure to meet contractual delivery dates if the Corporation caused the delay and the delay was not excusable. The Corporation would be liable for liquidated damages if the Corporation was deemed responsible for not meeting the delivery dates. On October 10, 2013, the Corporation received a letter from WEC stating entitlements to the maximum amount of liquidated damages allowable under the AP1000 China contract from WEC

of approximately \$25 million. As of December 31, 2017, the Corporation has not met certain contractual delivery dates under its AP1000 U.S. and China contracts; however, there are significant counterclaims and uncertainties as to which parties are responsible for the delays. The Corporation believes it has adequate legal defenses and intends to vigorously defend this matter. Given the uncertainties surrounding the responsibility for the delays, no accrual has been made for this matter as of December 31, 2017. As of December 31, 2017, the range of possible loss is \$0 million to \$31 million for the AP1000 U.S. contract, for a total range of possible loss of \$0 to \$55.5 million.

19. ACCUMULATED OTHER COMPREHENSIVE INCOME (LOSS)

The total cumulative balance of each component of accumulated other comprehensive income (loss), net of tax, is as follows:

| <i>(In thousands)</i> | Foreign currency translation adjustments, net | Total pension and postretirement adjustments, net | Accumulated other comprehensive income (loss) |
|---|--|--|--|
| December 31, 2015 | \$(107,810) | \$(118,118) | \$(225,928) |
| Other comprehensive loss before reclassifications ⁽¹⁾ | (64,840) | (7,892) | (72,732) |
| Amounts reclassified from accumulated other comprehensive income ⁽¹⁾ | — | 6,904 | 6,904 |
| Net current period other comprehensive loss | (64,840) | (988) | (65,828) |
| December 31, 2016 | \$(172,650) | \$(119,106) | \$(291,756) |
| Other comprehensive loss before reclassifications ⁽¹⁾ | 77,942 | (10,831) | 67,111 |
| Amounts reclassified from accumulated other comprehensive income ⁽¹⁾ | — | 7,805 | 7,805 |
| Net current period other comprehensive income (loss) | 77,942 | (3,026) | 74,916 |
| December 31, 2017 | \$ (94,708) | \$(122,132) | \$(216,840) |

⁽¹⁾ All amounts are after tax.

Details of amounts reclassified from accumulated other comprehensive income (loss) are below:

| <i>(In thousands)</i> | Amount reclassified from Accumulated other comprehensive income (loss) | | Affected line item in the statement where net earnings is presented |
|--|---|-------------------|---|
| | 2017 | 2016 | |
| Defined benefit pension and postretirement plans | | | |
| Amortization of prior service costs | 756 | 703 | (1) |
| Amortization of net actuarial losses | (12,702) | (11,733) | (1) |
| Settlements | (327) | — | (1) |
| | (12,273) | (11,030) | Total before tax |
| | 4,468 | 4,126 | Income tax effect |
| Total reclassifications | <u>\$ (7,805)</u> | <u>\$ (6,904)</u> | Net of tax |

⁽¹⁾ These items are included in the computation of net periodic pension cost. See Note 15, Pension and Other Postretirement Benefit Plans.

20. QUARTERLY RESULTS OF OPERATIONS (UNAUDITED)

The following tables set forth selected unaudited quarterly Consolidated Statements of Earnings information for the fiscal years ended December 31, 2017 and 2016.

| <i>(In thousands, except per share data)</i> | First | Second | Third | Fourth |
|--|--------------|---------------|--------------|---------------|
| 2017 | | | | |
| Net sales | \$523,591 | \$567,653 | \$567,901 | \$611,881 |
| Gross profit | 170,775 | 198,770 | 210,783 | 238,267 |
| Earnings from continuing operations | 32,547 | 50,650 | 63,944 | 67,750 |
| Loss from discontinued operations | — | — | — | — |
| Net earnings | 32,547 | 50,650 | 63,944 | 67,750 |
| Basic earnings per share | | | | |
| Earnings from continuing operations | \$ 0.74 | \$ 1.15 | \$ 1.45 | \$ 1.54 |
| Loss from discontinued operations | \$ — | \$ — | \$ — | \$ — |
| Total | \$ 0.74 | \$ 1.15 | \$ 1.45 | \$ 1.54 |
| Diluted earnings per share | | | | |
| Earnings from continuing operations | \$ 0.73 | \$ 1.13 | \$ 1.43 | \$ 1.52 |
| Loss from discontinued operations | \$ — | \$ — | \$ — | \$ — |
| Total | \$ 0.73 | \$ 1.13 | \$ 1.43 | \$ 1.52 |
| 2016 | | | | |
| Net sales | \$503,507 | \$532,766 | \$507,092 | \$565,566 |
| Gross profit | 171,903 | 185,379 | 184,476 | 208,725 |
| Earnings from continuing operations | 32,819 | 39,963 | 45,932 | 70,668 |
| Loss from discontinued operations | — | — | — | (2,053) |
| Net earnings | 32,819 | 39,963 | 45,932 | 68,615 |
| Basic earnings per share | | | | |
| Earnings from continuing operations | \$ 0.74 | \$ 0.90 | \$ 1.04 | \$ 1.60 |
| Loss from discontinued operations | — | — | — | (0.05) |
| Total | \$ 0.74 | \$ 0.90 | \$ 1.04 | \$ 1.55 |
| Diluted earnings per share | | | | |
| Earnings from continuing operations | \$ 0.73 | \$ 0.88 | \$ 1.02 | \$ 1.58 |
| Loss from discontinued operations | — | — | — | (0.05) |
| Total | \$ 0.73 | \$ 0.88 | \$ 1.02 | \$ 1.53 |

Note: Certain amounts may not add due to rounding.

21. SUBSEQUENT EVENTS

On February 13, 2018, the Corporation made a voluntary \$50 million contribution to the CW Pension Plan.

On February 20, 2018, the Corporation announced that it entered into an agreement to acquire the assets of the Dresser-Rand Government Business (Dresser-Rand) for \$212.5 million in cash. Dresser-Rand operates as a business unit of Siemens Government Technologies, which is a wholly-owned U.S. subsidiary of Siemens AG in Germany. Dresser-Rand is a leading designer and manufacturer of mission-critical, high-speed rotating equipment solutions and also acts as the sole supplier of steam turbines and main engine guard valves on all aircraft carrier programs. The acquired business will operate within the Corporation's Power segment.

* * * * *

Report of the Corporation

The Consolidated Financial Statements appearing in Item 8 of this Annual Report on Form 10-K have been prepared by the Corporation in conformity with accounting principles generally accepted in the United States of America. The financial statements necessarily include some amounts that are based on the best estimates and judgments of the Corporation. Other financial information in this Annual Report on Form 10-K is consistent with that in the Consolidated Financial Statements.

The Corporation maintains accounting systems, procedures, and internal accounting controls designed to provide reasonable assurance that assets are safeguarded and that transactions are executed in accordance with the appropriate corporate authorization and are properly recorded. The accounting systems and internal accounting controls are augmented by written policies and procedures, organizational structure providing for a division of responsibilities, selection and training of qualified personnel, and an internal audit program. The design, monitoring, and revision of internal accounting control systems involve, among other things, management's judgment with respect to the relative cost and expected benefits of specific control measures. Management of the Corporation has completed an assessment of the Corporation's internal controls over financial reporting and has included "Management's Annual Report on Internal Control Over Financial Reporting" in Item 9A of this Annual Report on Form 10-K.

Deloitte & Touche LLP, our independent registered public accounting firm, performed an integrated audit of the Corporation's Consolidated Financial Statements that also included forming an opinion on the internal controls over financial reporting of the Corporation for the year ended December 31, 2017. An audit includes examining, on a test basis, evidence supporting the amounts and disclosures in the financial statements. An audit also includes assessing the accounting principles used and significant estimates made by management, as well as evaluating the overall financial statement presentation. The objective of their audit is the expression of an opinion on the fairness of the Corporation's Consolidated Financial Statements in conformity with accounting principles generally accepted in the United States of America, in all material respects, and on the internal controls over financial reporting as of December 31, 2017.

The Audit Committee of the Board of Directors, composed entirely of directors who are independent of the Corporation, appoints the independent registered public accounting firm for ratification by stockholders and, among other things, considers the scope of the independent registered public accounting firm's examination, the audit results, and the adequacy of internal accounting controls of the Corporation. The independent registered public accounting firm and the internal auditor have direct access to the Audit Committee, and they meet with the committee from time to time, with and without management present, to discuss accounting, auditing, non-audit consulting services, internal control, and financial reporting matters.

Report of Independent Registered Public Accounting Firm

To the Shareholders and Board of Directors of
Curtiss-Wright Corporation

Opinion on the Financial Statements

We have audited the accompanying consolidated balance sheets of Curtiss-Wright Corporation and subsidiaries (the “Company”) as of December 31, 2017 and 2016, and the related consolidated statements of earnings, comprehensive income, stockholders’ equity, and cash flows for each of the three years in the period ended December 31, 2017, and the related notes and the schedule listed in the Index at Item 15 (collectively referred to as the “financial statements”). In our opinion, the financial statements present fairly, in all material respects, the financial position of the Company as of December 31, 2017 and 2016, and the results of its operations and its cash flows for each of the three years in the period ended December 31, 2017, in conformity with accounting principles generally accepted in the United States of America.

We have also audited, in accordance with the standards of the Public Company Accounting Oversight Board (United States) (PCAOB), the Company’s internal control over financial reporting as of December 31, 2017, based on criteria established in *Internal Control - Integrated Framework (2013)* issued by the Committee of Sponsoring Organizations of the Treadway Commission and our report dated February 22, 2018, expressed an unqualified opinion on the Company’s internal control over financial reporting.

Basis for Opinion

These financial statements are the responsibility of the Company’s management. Our responsibility is to express an opinion on the Company’s financial statements based on our audits. We are a public accounting firm registered with the PCAOB and are required to be independent with respect to the Company in accordance with the U.S. federal securities laws and the applicable rules and regulations of the Securities and Exchange Commission and the PCAOB.

We conducted our audits in accordance with the standards of the PCAOB. Those standards require that we plan and perform the audit to obtain reasonable assurance about whether the financial statements are free of material misstatement, whether due to error or fraud. Our audits included performing procedures to assess the risks of material misstatement of the financial statements, whether due to error or fraud, and performing procedures that respond to those risks. Such procedures included examining, on a test basis, evidence regarding the amounts and disclosures in the financial statements. Our audits also included evaluating the accounting principles used and significant estimates made by management, as well as evaluating the overall presentation of the financial statements. We believe that our audits provide a reasonable basis for our opinion.

/s/ Deloitte & Touche LLP

Parsippany, New Jersey
February 22, 2018

We have served as the Company’s auditor since 2003.

Report of Independent Registered Public Accounting Firm

To the Shareholders and Board of Directors of
Curtiss-Wright Corporation

Opinion on Internal Control over Financial Reporting

We have audited the internal control over financial reporting of Curtiss-Wright Corporation and subsidiaries (the "Company") as of December 31, 2017, based on criteria established in *Internal Control - Integrated Framework (2013)* issued by the Committee of Sponsoring Organizations of the Treadway Commission (COSO). In our opinion, the Company maintained, in all material respects, effective internal control over financial reporting as of December 31, 2017, based on criteria established in *Internal Control - Integrated Framework (2013)* issued by COSO.

We have also audited, in accordance with the standards of the Public Company Accounting Oversight Board (United States) (PCAOB), the consolidated financial statements as of and for the year ended December 31, 2017, of the Company and our report dated February 22, 2018, expressed an unqualified opinion on those financial statements.

Basis for Opinion

The Company's management is responsible for maintaining effective internal control over financial reporting and for its assessment of the effectiveness of internal control over financial reporting, included in the accompanying Management's Annual Report on Internal Control Over Financial Reporting. Our responsibility is to express an opinion on the Company's internal control over financial reporting based on our audit. We are a public accounting firm registered with the PCAOB and are required to be independent with respect to the Company in accordance with the U.S. federal securities laws and the applicable rules and regulations of the Securities and Exchange Commission and the PCAOB.

We conducted our audit in accordance with the standards of the PCAOB. Those standards require that we plan and perform the audit to obtain reasonable assurance about whether effective internal control over financial reporting was maintained in all material respects. Our audit included obtaining an understanding of internal control over financial reporting, assessing the risk that a material weakness exists, testing and evaluating the design and operating effectiveness of internal control based on the assessed risk, and performing such other procedures as we considered necessary in the circumstances. We believe that our audit provides a reasonable basis for our opinion.

Definition and Limitations of Internal Control over Financial Reporting

A company's internal control over financial reporting is a process designed to provide reasonable assurance regarding the reliability of financial reporting and the preparation of financial statements for external purposes in accordance with generally accepted accounting principles. A company's internal control over financial reporting includes those policies and procedures that (1) pertain to the maintenance of records that, in reasonable detail, accurately and fairly reflect the transactions and dispositions of the assets of the company; (2) provide reasonable assurance that transactions are recorded as necessary to permit preparation of financial statements in accordance with generally accepted accounting principles, and that receipts and expenditures of the company are being made only in accordance with authorizations of management and directors of the company; and (3) provide reasonable assurance regarding prevention or timely detection of unauthorized acquisition, use, or disposition of the company's assets that could have a material effect on the financial statements.

Because of its inherent limitations, internal control over financial reporting may not prevent or detect misstatements. Also, projections of any evaluation of effectiveness to future periods are subject to the risk that controls may become inadequate because of changes in conditions, or that the degree of compliance with the policies or procedures may deteriorate.

/s/ Deloitte & Touche LLP

Parsippany, New Jersey
February 22, 2018

Item 9. Changes in and Disagreements with Accountants on Accounting and Financial Disclosure.

None.

Item 9A. Controls and Procedures.

Disclosure Controls and Procedures

As of December 31, 2017, the Corporation's management, including the Corporation's Chief Executive Officer and Chief Financial Officer, conducted an evaluation of the Corporation's disclosure controls and procedures, as such term is defined in Rules 13a-15(e) and 15d-15(e) under the Securities Exchange Act of 1934, as amended (the "Exchange Act"). Based on such evaluation, the Corporation's Chief Executive Officer and Chief Financial Officer concluded that the Corporation's disclosure controls and procedures are effective as of December 31, 2017 insofar as they are designed to ensure that information required to be disclosed by us in the reports that we file or submit under the Exchange Act is recorded, processed, summarized and reported, within the time periods specified in the Commission's rules and forms, and they include, without limitation, controls and procedures designed to ensure that information required to be disclosed by us in the reports we file or submit under the Exchange Act is accumulated and communicated to our management, including our principal executive and principal financial officers, or persons performing similar functions, as appropriate to allow timely decisions regarding required disclosure.

Management's Annual Report On Internal Control Over Financial Reporting

The Corporation's management is responsible for establishing and maintaining adequate internal control over financial reporting, as defined in Rules 13a-15(f) and 15d-15(f) under the Securities Exchange Act of 1934, as amended.

Because of its inherent limitations, internal control over financial reporting may not prevent or detect misstatements. Also, projections of the future effectiveness of controls currently deemed effective are subject to the risk that controls may become inadequate because of changes in conditions or deterioration in the degree of compliance with the policies or procedures.

The Corporation's management assessed the effectiveness of the Corporation's internal control over financial reporting as of December 31, 2017. In making this assessment, the Corporation's management used the criteria established in *Internal Control - Integrated Framework (2013)* issued by the Committee of Sponsoring Organizations of the Treadway Commission.

Based on management's assessment, management believes that as of December 31, 2017, the Corporation's internal control over financial reporting is effective based on the established criteria.

The Corporation's internal controls over financial reporting as of December 31, 2017 have been audited by Deloitte & Touche LLP, an independent registered public accounting firm, and their report thereon is included in Item 8 of this Annual Report on Form 10-K.

Changes in Internal Control over Financial Reporting

During the year ended December 31, 2017, we modified existing internal controls as well as implemented new controls as part of our efforts to adopt the new revenue recognition standard which becomes effective on January 1, 2018. Those efforts resulted in the enhancement of our risk assessment process whereby we designed new controls and modified existing controls to address risks associated with the five-step model for recognizing revenue under the new standard. There have not been any other changes in our internal control over financial reporting during the quarter ended or year ended December 31, 2017 that have materially affected, or are reasonably likely to materially affect, our internal control over financial reporting.

Item 9B. Other Information.

None.

PART III

The information required by Items 10, 11, 12, 13, and 14 of Part III of this Annual Report on Form 10-K, to the extent not set forth herein, is incorporated herein by reference from the registrant's definitive proxy statement relating to the annual meeting of stockholders to be held on May 10, 2018 which definitive proxy statement shall be filed with the Securities and Exchange Commission within 120 days after the end of the fiscal year to which this report relates. Information required by Item 401(b) of Regulation S-K is included in Part I of this report under the caption "Executive Officers" and information required by Item 201(d) of Regulation S-K is included in Part II of this report under the caption "Securities Authorized For Issuance Under Equity Compensation Plans."

PART IV

Item 15. Exhibits, Financial Statement Schedule.

| (a) | Financial Statements and Footnotes | Page |
|-----|--|------|
| 1. | The following are documents filed as part of this report in Part II, Item 8: | |
| | Consolidated Statements of Earnings | 41 |
| | Consolidated Statements of Comprehensive Income | 42 |
| | Consolidated Balance Sheets | 43 |
| | Consolidated Statements of Cash Flows | 44 |
| | Consolidated Statements of Stockholders' Equity | 45 |
| | Notes to Consolidated Financial Statements | 46 |
| 2. | Financial Statement Schedule | |
| | Schedule II-Valuation and Qualifying Accounts | 91 |
| | All other financial statement schedules have been omitted because they are either not required, not applicable or the required information is shown in the Consolidated Financial Statements or Notes thereto. | |

| (b) | | Exhibits | | Filed |
|-------------|--|---------------------------|-------------------|----------|
| Exhibit No. | Exhibit Description | Incorporated by Reference | | Herewith |
| | | Form | Filing Date | |
| 2.1 | Agreement and Plan of Merger and Recapitalization, dated as of February 1, 2005, by and between the Registrant and CW Merger Sub, Inc. | 8-K | February 3, 2005 | |
| 3.1 | Amended and Restated Certificate of Incorporation | 8-A/A | May 24, 2005 | |
| 3.2 | Amended and Restated By-Laws | 8-K | May 18, 2015 | |
| 4.1 | Form of stock certificate for Common Stock | 8-A/A | May 24, 2005 | |
| 10.1 | Curtiss-Wright Corporation 2005 Omnibus Long-Term Incentive Plan, amended and restated effective January 1, 2010* | 14A | March 19, 2010 | |
| 10.2 | Form of Long Term Incentive Award Agreement, between the Registrant and the executive officers of the Registrant* | 10-K | March 7, 2006 | |
| 10.3 | Revised Standard Employment Severance Agreement with Senior Management of the Registrant* | 10-Q | August 15, 2001 | |
| 10.4 | Amended and Restated Retirement Benefits Restoration Plan as amended January 1, 2009.* | 10-K | February 25, 2011 | |
| 10.5 | Instrument of Amendment No. 1 to Amended and Restated Retirement Benefits Restoration Plan as amended January 1, 2009* | 10-K | February 24, 2012 | |
| 10.6 | Instrument of Amendment No. 2 to Amended and Restated Retirement Benefits Restoration Plan as amended January 1, 2009* | 10-K | February 19, 2015 | |
| 10.7 | Instrument of Amendment No. 3 to Amended and Restated Retirement Benefits Restoration Plan as amended January 1, 2009* | 10-K | February 19, 2015 | |
| 10.8 | Instrument of Amendment No. 4 to Amended and Restated Retirement Benefits Restoration Plan as amended January 1, 2009* | 10-K | February 25, 2016 | |

| Exhibit No. | Exhibit Description | Incorporated by Reference | | Filed Herewith |
|-------------|---|---------------------------|-------------------|----------------|
| | | Form | Filing Date | |
| 10.9 | Curtiss-Wright Corporation Retirement Plan, as Amended and Restated January 1, 2015* | 10-K | February 25, 2016 | |
| 10.10 | Instrument of Amendment No. 1 to Curtiss-Wright Corporation Retirement Plan, as Amended and Restated January 1, 2015* | 10-K | February 21, 2017 | |
| 10.11 | Instrument of Amendment No. 2 to Curtiss-Wright Corporation Retirement Plan, as Amended and Restated January 1, 2015* | 10-K | February 21, 2017 | |
| 10.12 | Instrument of Amendment No. 3 to Curtiss-Wright Corporation Retirement Plan, as Amended and Restated January 1, 2015* | | | X |
| 10.13 | Instrument of Amendment No. 4 to Curtiss-Wright Corporation Retirement Plan, as Amended and Restated January 1, 2015* | | | X |
| 10.14 | Curtiss-Wright Corporation Savings and Investment Plan, as Amended and Restated effective as of January 1, 2015* | 10-K | February 25, 2016 | |
| 10.15 | Instrument of Amendment No. 1 to the Curtiss-Wright Corporation Savings and Investment Plan, as Amended and Restated effective January 1, 2015* | 10-K | February 25, 2016 | |
| 10.16 | Instrument of Amendment No. 2 to the Curtiss-Wright Corporation Savings and Investment Plan, as Amended and Restated effective January 1, 2015* | 10-K | February 21, 2017 | |
| 10.17 | Instrument of Amendment No. 3 to the Curtiss-Wright Corporation Savings and Investment Plan, as Amended and Restated effective January 1, 2015* | 10-K | February 21, 2017 | |
| 10.18 | Instrument of Amendment No. 4 to the Curtiss-Wright Corporation Savings and Investment Plan, as Amended and Restated effective January 1, 2015* | 10-K | February 21, 2017 | |
| 10.19 | Instrument of Amendment No. 5 to the Curtiss-Wright Corporation Savings and Investment Plan, as Amended and Restated effective January 1, 2015* | | | X |
| 10.20 | Instrument of Amendment No. 6 to the Curtiss-Wright Corporation Savings and Investment Plan, as Amended and Restated effective January 1, 2015* | | | X |
| 10.21 | Curtiss-Wright Corporation 2014 Omnibus Incentive Plan* | 14A | March 21, 2014 | |
| 10.22 | Curtiss-Wright Corporation Retirement Savings Restoration Plan* | 10-K | February 19, 2015 | |
| 10.23 | Instrument of Amendment No. 1 to the Curtiss-Wright Corporation Retirement Savings Restoration Plan* | 10-K | February 25, 2016 | |
| 10.24 | Form of indemnification Agreement entered into by the Registrant with each of its directors | 10-Q | May 7, 2012 | |

| Exhibit No. | Exhibit Description | Incorporated by Reference | | Filed Herewith |
|-------------|---|---------------------------|-------------------|----------------|
| | | Form | Filing Date | |
| 10.25 | Amended and Restated Curtiss-Wright Electro-Mechanical Corporation Savings Plan, dated January 1, 2010* | 10-K | February 25, 2011 | |
| 10.26 | Instrument of Amendment No.1 to the Amended and Restated Curtiss-Wright Electro-Mechanical Corporation Savings Plan, dated January 1, 2010* | 10-K | February 24, 2012 | |
| 10.27 | Instrument of Amendment No. 2 to the Amended and Restated Curtiss-Wright Electro-Mechanical Corporation Savings Plan, dated January 1, 2010* | 10-K | February 21, 2013 | |
| 10.28 | Instrument of Amendment No.3 to the Amended and Restated Curtiss-Wright Electro-Mechanical Corporation Savings Plan, dated January 1, 2010* | 10-K | February 21, 2013 | |
| 10.29 | Instrument of Amendment No.4 to the Amended and Restated Curtiss-Wright Electro-Mechanical Corporation Savings Plan, dated January 1, 2010* | 10-K | February 21, 2014 | |
| 10.30 | Curtiss-Wright Corporation 2005 Stock Plan for Non-Employee Directors* | 14A | April 5, 2005 | |
| 10.31 | Amended and Revised Curtiss-Wright Corporation Executive Deferred Compensation Plan, as amended November 2006* | 10-K | February 27, 2007 | |
| 10.32 | Instrument of Amendment No. 1 to the Amended and Revised Curtiss-Wright Corporation Executive Deferred Compensation Plan, as amended August 29, 2008* | 10-K | February 24, 2012 | |
| 10.33 | Instrument of Amendment No. 2 to the Amended and Revised Curtiss-Wright Corporation Executive Deferred Compensation Plan, as amended August 29, 2008* | 10-K | February 19, 2015 | |
| 10.34 | Instrument of Amendment No. 3 to the Amended and Revised Curtiss-Wright Corporation Executive Deferred Compensation Plan, as amended August 29, 2008* | 10-K | February 25, 2016 | |
| 10.35 | Standard Change In Control Severance Protection Agreement, dated July 9, 2001, between the Registrant and Key Executives of the Registrant* | 10-Q | November 15, 2001 | |
| 10.36 | Curtiss-Wright Corporation Employee Stock Purchase Plan* | 14A | March 24, 2011 | |
| 10.37 | Incentive Compensation Plan, as amended November 15, 2010* | 14A | March 24, 2011 | |
| 10.38 | Restricted Stock Unit Agreement, dated April 1, 2013, by and between the Registrant and Thomas Quinly* | 10-Q | May 2, 2013 | |
| 10.39 | Trust Agreement, dated January 20, 1998, between the Registrant and PNC Bank, National Association | 10-Q | May 13, 1998 | |
| 10.40 | Note Purchase Agreement between the Registrant and certain Institutional Investors, dated December 8, 2011 | 8-K | December 13, 2011 | |

| Exhibit No. | Exhibit Description | Incorporated by Reference | | Filed Herewith |
|-------------|---|---------------------------|-------------------|----------------|
| | | Form | Filing Date | |
| 10.41 | Restrictive Legends on Notes subject to Note Purchase Agreement between the Registrant and certain Institutional Investors, dated December 8, 2011 | 8-K | December 13, 2011 | |
| 10.42 | Note Purchase Agreement between the Registrant and certain Institutional Investors, dated February 26, 2013 | 8-K | February 27, 2013 | |
| 10.43 | Restrictive Legends on Notes subject to Note Purchase Agreement between the Registrant and certain Institutional Investors, dated February 26, 2013 | 8-K | February 27, 2013 | |
| 10.44 | Third Amended and Restated Credit Agreement dated as of August 9, 2012 among the Registrant, and Certain Subsidiaries as Borrowers; the Lenders parties thereto; Bank of America, N.A., as Administrative Agent; Swingline Lender, and L/C Issuer; J.P. Morgan Chase Bank, N.A., and Wells Fargo, N.A., as Syndication Agents; and RBS Citizens, N.A., as Documentation Agent | 8-K | August 13, 2012 | |
| 10.45 | First Amendment dated July 28, 2014 to Third Amended and Restated Credit Agreement dated as of August 9, 2012 among the Registrant, and Certain Subsidiaries as Borrowers; the Lenders parties thereto; Bank of America, N.A., as Administrative Agent; Swingline Lender, and L/C Issuer; J.P. Morgan Chase Bank, N.A., and Wells Fargo, N.A., as Syndication Agents; and RBS Citizens, N.A., as Documentation Agent | 10-K | February 19, 2015 | |
| 10.46 | Second Amendment dated December 12, 2014 to Third Amended and Restated Credit Agreement dated as of August 9, 2012 among the Registrant, and Certain Subsidiaries as Borrowers; the Lenders parties thereto; Bank of America, N.A., as Administrative Agent; Swingline Lender, and L/C Issuer; J.P. Morgan Chase Bank, N.A., and Wells Fargo, N.A., as Syndication Agents; and RBS Citizens, N.A., as Documentation Agent | 10-K | February 19, 2015 | |
| 10.47 | Third Amendment dated June 16, 2015 to Third Amended and Restated Credit Agreement dated as of August 9, 2012 among the Registrant, and Certain Subsidiaries as Borrowers; the Lenders parties thereto; Bank of America, N.A., as Administrative Agent; Swingline Lender, and L/C Issuer; J.P. Morgan Chase Bank, N.A., and Wells Fargo, N.A., as Syndication Agents; and RBS Citizens, N.A., as Documentation Agent | 8-K | June 18, 2015 | |
| 21.00 | Subsidiaries of the Registrant | | | X |
| 23.00 | Consent of Independent Registered Public Accounting Firm | | | X |
| 31.10 | Certification of David C. Adams, Chairman and CEO, Pursuant to Rule 13a - 14(a) | | | X |

| Exhibit No. | Exhibit Description | Incorporated by Reference | | Filed Herewith |
|----------------|---|---------------------------|-------------|-------------------|
| | | Form | Filing Date | |
| 31.20 | Certification of Glenn E. Tynan, Chief Financial Officer, Pursuant to Rule 13a - 14(a) | | | X |
| 32.00 | Certification of David C. Adams, Chairman and CEO and Glenn E. Tynan, Chief Financial Officer, Pursuant to 18 U.S.C. Section 1350 | | | X |
| * | Indicates contract or compensatory plan or arrangement | | | |
| 101.INS | XBRL Instance Document | | | |
| 101.SCH | XBRL Taxonomy Extension Schema Document | | | |
| 101.CAL | XBRL Taxonomy Extension Calculation Linkbase Document | | | |
| 101.DEF | XBRL Taxonomy Extension Definition Linkbase Document | | | |
| 101.LAB | XBRL Taxonomy Extension Label Linkbase Document | | | |
| 101.PRE | XBRL Taxonomy Extension Presentation Linkbase Document | | | |

CURTISS-WRIGHT CORPORATION and SUBSIDIARIES
SCHEDULE II – VALUATION and QUALIFYING ACCOUNTS
for the years ended December 31, 2017, 2016, and 2015
(In thousands)

| Description | Balance at Beginning of Period | Additions | | Deductions | Balance at End of Period |
|---|---|-------------------------------------|---------------------------------|----------------------|--------------------------------|
| | | Charged to Costs and Expenses | Charged to Other Accounts | | |
| Deducted from assets to which they apply: | | | | | |
| December 31, 2017 | | | | | |
| Tax valuation allowance | 17,776 | 1,471 | 125 ⁽¹⁾ | 7,050 ⁽³⁾ | 12,322 |
| Total | <u>\$17,776</u> | <u>\$ 1,471</u> | <u>\$ 125</u> | <u>\$7,050</u> | <u>\$12,322</u> |
| December 31, 2016 | | | | | |
| Tax valuation allowance | 17,895 | 1,951 | (181) ⁽¹⁾ | 1,889 ⁽²⁾ | 17,776 |
| Total | <u>\$17,895</u> | <u>\$ 1,951</u> | <u>\$ (181)</u> | <u>\$1,889</u> | <u>\$17,776</u> |
| December 31, 2015 | | | | | |
| Tax valuation allowance | 23,478 | 2,605 | (299) ⁽¹⁾ | 7,889 | 17,895 |
| Total | <u>\$23,478</u> | <u>\$ 2,605</u> | <u>\$ (299)</u> | <u>\$7,889</u> | <u>\$17,895</u> |

⁽¹⁾ Primarily foreign currency translation adjustments.

⁽²⁾ Capital loss on sale of upstream oil and gas business.

⁽³⁾ \$4.3 million relates to the reduction of the U.S. corporate income tax rate due to the Tax Act.

SHAREHOLDER INFORMATION

Corporate Headquarters

130 Harbour Place Drive, Suite 300
Davidson, N.C. 28036
www.curtisswright.com
Tel: (704) 869-4600

Annual Meeting

The 2018 annual meeting of stockholders will be held on Thursday, May 10, 2018, at the Homewood Suites by Hilton, 125 Harbour Place Drive, Davidson, N.C., 28036, commencing at 10:00 a.m. local time.

Stock Exchange Listing

The Corporation's common stock is listed and traded on the New York Stock Exchange under the symbol CW.

Common Shareholders

As of December 31, 2017, the approximate number of registered holders of record of common stock, par value of \$1.00 per share of the Corporation, was 3,532.

Forward-Looking Statements

This brochure contains not only historical information, but also forward-looking statements regarding expectations of future performance of the Corporation. Forward-looking statements involve risk and uncertainty. Please refer to the Corporation's 2017 Annual Report on Form 10-K for a discussion relating to forward-looking statements contained in this brochure and risk factors that could cause future results to differ from current expectations.

Stock Transfer Agent and Registrar

For services such as changes of address, replacement of lost certificates or dividend checks, and changes in registered ownership, or for inquiries as to account status, write to: Broadridge Corporate Issuer Solutions, Inc., P.O. Box 1342, Brentwood, N.Y. 11717 or overnight to 1155 Long Island Avenue, Brentwood, N.Y. 11717. Please include your name, address and telephone number with all correspondence. Telephone inquiries may be made toll-free to (855) 449-0995, or to (720) 864-4772 internationally. Internet inquiries should be directed to <http://shareholder.broadridge.com/curtisswright> and by email to shareholder@broadridge.com. Hearing-impaired shareholders are invited to log on to the website and select the Live Chat option.

Direct Stock Purchase Plan/ Dividend Reinvestment Plan

A plan is available to purchase or sell shares of Curtiss-Wright common stock. The plan provides a low-cost alternative to the traditional methods of buying, holding and selling stock. The plan also provides for the automatic reinvestment of Curtiss-Wright dividends. For more information, contact our transfer agent, Broadridge Corporate Issuer Solutions, Inc., P.O. Box 1342, Brentwood, N.Y. 11717, toll-free at (855) 449-0995.

Investor Information

Investors, stockbrokers, security analysts and others seeking information about Curtiss-Wright Corporation should contact James M. Ryan, Senior Director of Investor Relations, at (704) 869-4600 or investor@curtisswright.com.

Shareholder Communications

Any stockholder wishing to communicate directly with our Board of Directors should write to John B. Nathman, c/o Curtiss-Wright Corporation, 130 Harbour Place Drive, Suite 300, Davidson, N.C. 28036.

Financial Reports

This brochure includes some of the periodic financial information required to be on file with the Securities and Exchange Commission. The Corporation also files an Annual Report on Form 10-K, a copy of which may be obtained free of charge. These reports, as well as additional financial documents such as quarterly shareholder reports, proxy statements, and quarterly reports on Form 10-Q, may be obtained by written request to James M. Ryan, Senior Director of Investor Relations, at the Corporate Headquarters or through the Investor Relations section of the Corporation's website: www.curtisswright.com.

**CURTISS -
WRIGHT**

Curtiss-Wright Corporation

130 Harbour Place Drive, Suite 300
Davidson, N.C. 28036

www.curtisswright.com

